

GIMMI®



Endoscopic Technology

**Endo-Chirurgie
Endo-Surgery
Endo-Cirugía
Endo-Chirurgia**





reddot design award
winner 2003



Designpreis der
Bundesrepublik
Deutschland
Nominiert 2004

zertifiziert nach:

ISO 13485, DIN EN 60601-1, ISO 9001, Richtlinie Nr. 93/42/EWG

certified according to:

ISO 13485, DIN EN 60601-1, ISO 9001, Council Directive 93/42/EEC

Certificado conforme a:

ISO 13485, DIN EN 60601-1, ISO 9001, Directiva nº 93/42/CEE

certificato secondo:

ISO 13485, DIN EN 60601-1, ISO 9001, Direttiva n. 93/42/CEE

Technische Änderungen vorbehalten

Dieser Prospekt/Katalog darf ausschließlich zur Anbietung und dem An- und Verkauf unserer Erzeugnisse dienen. Nachdruck, auch auszugsweise, verboten.

Bei Missbrauch behalten wir uns Rücknahme der Kataloge und Preislisten sowie Regressmaßnahmen vor.

Technical modifications reserved.

This brochure/catalog is intended for preparation of offers and purchase and sale of our products only. Any reproduction of its contents, as a whole or in part, is not permitted.

In case of misuse we may reclaim the catalog and price lists and reserve the right to take legal actions.

Se reserva cualquier modificación técnica.

El único fin de este prospecto/catálogo es la preparación de ofertas y la compra y venta de nuestros productos. Queda totalmente prohibida la impresión total o parcial del mismo.

En caso de uso incorrecto nos reservamos el derecho a la retirada del catálogo y de las listas de precios y a tomar acciones legales.

Con riserva di modifiche tecniche

L'uso di questo prospetto/catalogo è esclusivamente destinato all'offerta, nonché alla vendita e all'acquisto dei nostri prodotti. È vietata qualsiasi riproduzione, anche parziale, dei suoi contenuti.

In caso di abuso, ci riserviamo il diritto di chiedere la restituzione dei cataloghi e dei listini prezzi, nonché il diritto di regresso.

GIMMI® KATALOGE / GIMMI® CATALOGUES / GIMMI® CATÁLOGOS / GIMMI® CATALOGHI



Cat. No. 100

Chirurgische Instrumente
Surgical instruments
Instrumental quirúrgico
Strumenti chirurgici



Cat. No. 120

Geräte
Units
Equipos
Apparecchiature



Cat. No. 122

Geräte
Units
Equipos
Apparecchiature



Cat. No. 130

Optiken / Kaltlichtkabel
Endoscopes / Fibre optic light cables
Ópticas / Cable de fibra óptica
Ottiche / Cavi luce fredda



Cat. No. 140

Endo-Chirurgie
Endo-Surgery
Endo-Cirugia
Endo-Chirurgia



Cat. No. 150

Gynäkologie
Gynaecology
Ginecología
Ginecologia



Cat. No. 170

Arthroskopie
Arthroscopy
Artroscopia
Artroscopia



Cat. No. 180

Moderne Arthrotomie & Arthroskopie
Modern arthrotomy & arthroscopy
Artrotomia e artroscopia moderna
Artrotomia e artroscopia moderna



Cat. No. 210

Mini- und Mikro Instrumente für die
Minimal Invasive Chirurgie nach Carbon
Mini and micro instruments for
minimally invasive surgery acc. Carbon
Instrumental Mini y Micro para la
Cirugía Mini Invasiva según Carbon
Strumenti Mini e Micro per la
Chirurgia Mini Invasiva secondo Carbon



Cat. No. 220

Bauch und Thoraxring-System für die
Kinderchirurgie und Mini Laparotomien nach Carbon
Abdomen and thorax ring system for pediatric surgery
and mini laparotomy acc. Carbon
Separador abdominal / torácico para cirugía pediátrica y
Mini Laparotomías según Carbon
Divaricatore addominale / toracico per chirurgia pediatrica
e per Mini-Laparotomie secondo Carbon



Cat. No. 240

Double Clipper
Double clipper
Double Clipper
Double Clipper



Cat. No. 250

Aneurysmen-Clips
Aneurysm clips
Clips para aneurisma
Clips per aneurisma

GIMMI® KATALOGE / GIMMI® CATALOGUES / GIMMI® CATÁLOGOS / GIMMI® CATALOGHI



Cat. No. 270

Hämorrhoidal-Ligatur Set
Haemorrhoidal ligator set
Set de ligadura para hemorroides
Set di legatura per emorroidi



Cat. No. 280

HF-Chirurgie Zubehör
Electrosurgical accessories
Accesorios para electrobisturías
Accessori per elettrobisturi



Cat. No. 290

WAYNE® Laminektomiestanze
WAYNE® Laminectomy punch
WAYNE® Pinza cortante para laminectomía
WAYNE® Pinza per laminectomia



Cat. No. 310

Steril Container System
Sterile container system
Sistema de contenedores para esterilización
Sistema di cestelli per sterilizzazione



Cat. No. 410

Neurochirurgie
Neurosurgery
Neurocirurgia
Neurochirurgia



Cat. No. 510

Sinuskopie
Sinuscopy
Sinuscopia
Sinuscopia

Inhaltsübersicht Table of Contents

Laparoskope / Fiberglas-Lichtleitkabel	Seite	1 - 8
Laparoscopes / Fibre optic light cables	Page	1 - 8



Trokare und Zubehör	Seite	9 - 27
Trocars and accessories	Page	9 - 27



Insufflationsnadeln	Seite	28
Insufflation needles	Page	28



Saug- und Spülsysteme	Seite	29 - 33
Suction and irrigation systems	Page	29 - 33



GIMMI® ALPHA - QUICK SYSTEM Instrumente	Seite	34 - 59
GIMMI® ALPHA - QUICK SYSTEM instruments	Page	34 - 59



Greif- und Faßzangen	Seite	60 - 62
Grasping forceps	Page	60 - 62



Mini-LAP Instrumente	Seite	63 - 64
Mini-LAP instruments	Page	63 - 64



Clipanlagezangen	Seite	65 - 66
Clip applicators	Page	65 - 66



Inhaltsübersicht Table of contents

Nadelhalter	Seite	67 - 70
Needle holders	Page	67 - 70



Knotenschnürer / Knotenschieber	Seite	71
Knot tighteners / Knot pushers	Page	71



Endo-Haken / Endo-Retraktoren	Seite	72 - 75
Endo-retractors	Page	72 - 75



Handgriffe für Saug- / Spülsystem	Seite	76
Handles for suction / irrigation system	Page	76



Monopolare HF-Elektroden / Monopolare Kabel	Seite	77 - 86
Monopolar HF-electrodes / Monopolar cables	Page	77 - 86

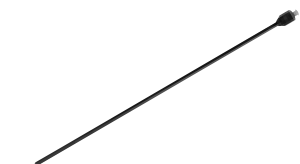

Bipolare Koagulations-Instrumente	Seite	87 - 95
Bipolar coagulation instruments	Page	87 - 95



Bipolare Koagulations-Elektroden / Bipolare Kabel	Seite	96 - 99
Bipolar coagulation electrodes / Bipolar cables	Page	96 - 99



Zubehör	Seite	100 - 104
Accessories	Page	100 - 104



Laparoskope Ø 5,5 mm und Ø 10,0 mm
Laparoscopes Ø 5,5 mm and Ø 10,0 mm

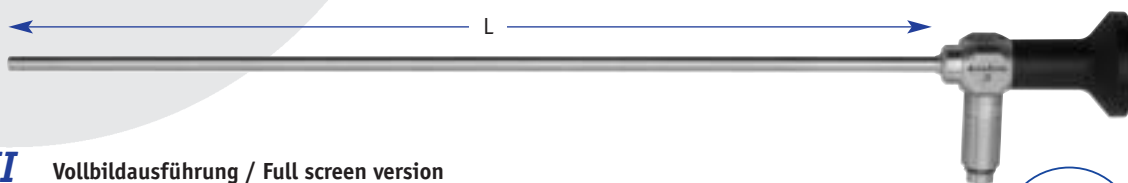

ALPHASCOPE II Vollbildausführung / Full screen version

E.8292.00	Ø 5,5 mm	L = 30 cm	0°
E.8292.30	Ø 5,5 mm	L = 30 cm	30°
E.8292.45	Ø 5,5 mm	L = 30 cm	45°



5,0 mm Ausführungen auf Anfrage lieferbar (nahezu Vollbild)
5.0 mm versions available on request (nearly full screen)



ALPHASCOPE II

E.8290.11	Ø 10,0 mm	L = 33 cm	0°
E.8293.11	Ø 10,0 mm	L = 33 cm	30°
E.8294.11	Ø 10,0 mm	L = 33 cm	45°



Operations-Laparoskope mit integriertem Instrumentenkanal Surgical laparoscopes with integrated instrument channel

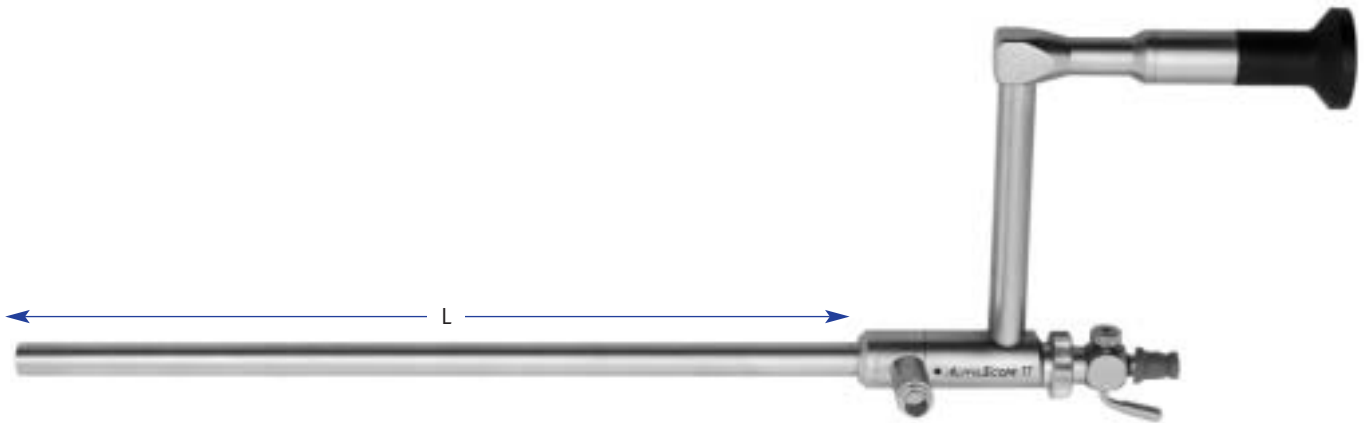

Operations-Laparoskop mit integriertem Instrumentenkanal (A), 0° - **Paralleleinblick** -einlegbar-
Surgical laparoscope with integrated instrument channel (A), 0° - **Parallel view** -soakable-

E.8280.10	∅ 10,0 mm	L = 27 cm	A = 5,1 mm	ALPHASCOPE II
E.8280.15	∅ 11,0 mm	L = 27 cm	A = 6,1 mm	ALPHASCOPE II

Operations-Laparoskop mit integriertem Instrumentenkanal (A), 0° - **Paralleleinblick**
Surgical laparoscope with integrated instrument channel (A), 0° - **Parallel view**

E.8280.12	∅ 10,0 mm	L = 27 cm	A = 6,1 mm	ALPHASCOPE
------------------	-----------	-----------	------------	-------------------

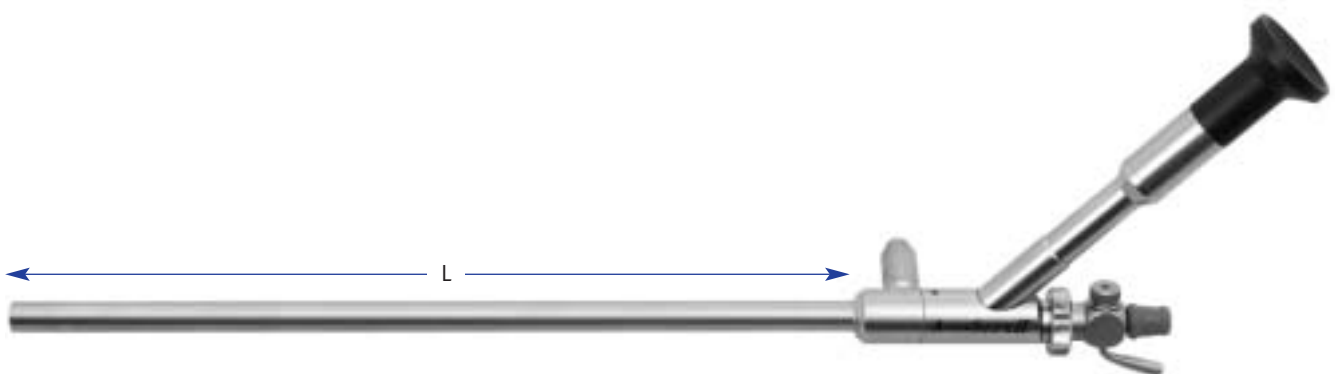

ALPHASCOPE II

Operations-Laparoskop mit integriertem Instrumentenkanal (A), 0° - **LAT (Lateraleinblick)** -einlegbar-
Operating laparoscope with integrated instrument channel (A), 0° - **LAT (Lateral view)** -soakable-

E.8280.20	∅ 10,0 mm	L = 27 cm	A = 5,1 mm
E.8280.30	∅ 11,0 mm	L = 27 cm	A = 6,1 mm

Endoskophalterungen Endoscope holders

E.8309.19

E.8309.50
Doppelsystem
Double system

E.8309.16



Die Endoskophalterung ist ideal zum einfachen, schnellen und genauen Positionieren und stabilen Fixieren des Endoskopes bei der minimal invasiven Chirurgie.

Alle 5 Gelenkpositionen werden mit einem Griff gespannt oder gelöst, was ein einfaches und schnelles Positionieren ermöglicht.

Die robuste Ausführung aus rostfreiem Stahl und hochwertigem Leichtmetall garantiert eine lange Lebensdauer.

Die Endoskophalterungen sind autoclavierbar bei 134°C.

Für den stabilen Halt des Endoskops und Retraktors sind Halterungen aus autoklavierbaren Materialien in verschiedenen Durchmessern erhältlich.

Vorteile:

- schnelle, einfache und präzise Positionierung
- keine kostspieligen Improvisationen
- ruhige Darstellung des Operationsfeldes
- Entlastung des Assistenten
- Verkürzung der Operationszeit

The endoscope holder is ideal for simple, accurate positioning and stable fixating of the endoscope in minimally invasive surgery.

One single action to lock and loosen all 5 joint functions offering an easy, handy and quick positioning.

The robust make in stainless steel and high-grade light metal guarantees a long, maintenance free, lifes. The endoscope holders are autoclavable (134°C).

For a stable fixation of the endoscopes and retractors, different holders in autoclavable materials and different diameters are available.

Advantages:

- fast, simple and precise positioning
- no expensive improvisation
- steady presentation of the surgical field
- relief for the assistant
- shortening of operating time

Endoskophalterungen Endoscope holders

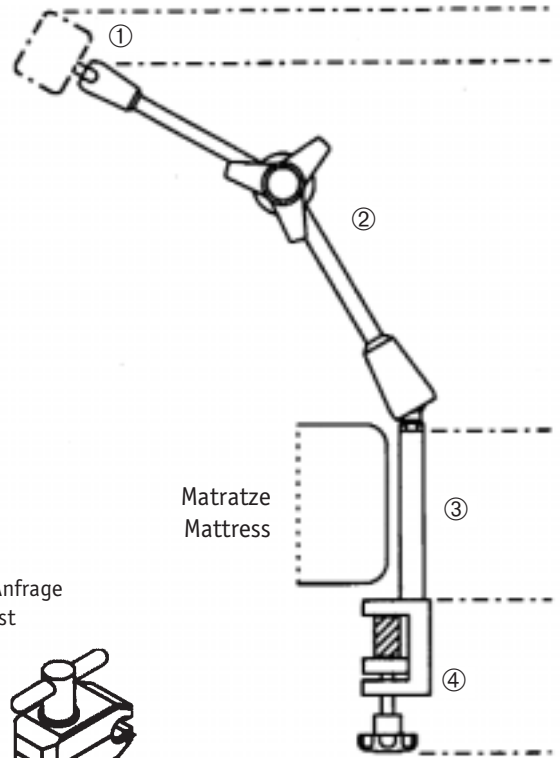

Andere Größen auf Anfrage
Other sizes on request

Optikhalterung, mit seitlicher Öffnung
Optic holder, with lateral insertion

E.8309.05	Ø 5,0 mm
E.8309.11	Ø 10,0 mm

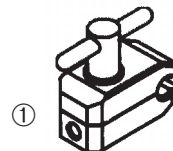

Gelenkstativ, Gewinde M8 / M12 x 1, Tragkraft 30 N
Articulated stand, thread M8 / M12 x 1, carrying capacity 30 N

	Aktionsradius Radius of action
E.8309.12	400 mm
E.8309.13	300 mm

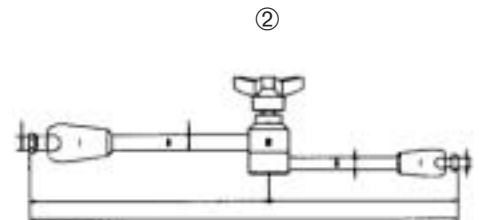

Säule, Gewinde M8 / M12 x 1
Column, thread M8 / M12 x 1

	L =	Ø 16 mm
E.8309.14	300 mm	Ø 16 mm
E.8309.24	400 mm	Ø 16 mm
E.8309.54	500 mm	Ø 16 mm

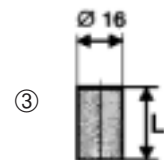

Schraubsockel aus Leichtmetall für höhenverstellbare Säule, Schienen 25 x 10 - 35 x 8 mm
Screw clamp base in light metal for height adjustable columns, rails 25 x 10 - 35 x 8 mm

E.8309.16	Ø 16 mm
------------------	---------

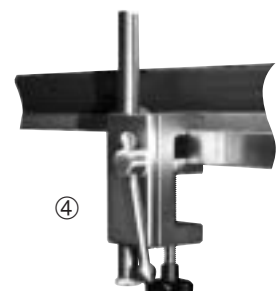

Endoskophalterungen Endoscope holders



Universal Wundhakenhalterung zu Endo-Haltesystemen
Universal retractor holder for endo-holdingsystem

E.8309.07



Optikhalterung mit seitlicher Öffnung
Scope holder, with lateral insertion

E.8309.10

Ø 8 mm

E.8309.11

Ø 10 mm



Universal Optikhalterung
Universal scope holder

E.8309.09

Ø 2 - 10 mm



Gelenkverlängerung, mit Feststellung
Extended articulation, lockable

E.8309.25

18 cm



Zweischlauchhalterung
Double tube holder

E.8309.27



Universal-Schlauchhalterungsplatte
Universal tube holding plate

E.8309.28



Endoskophalterungen Endoscope holders



Standard - Sets / standard sets

E.8309.00	Endoskophalterung, komplett bestehend aus: 1 Optikhalterung Ø 10 mm (E.8309.11) 1 Gelenkstativ 400 mm (E.8309.12) 1 Säule, 500 mm, Ø 16 mm (E.8309.54) 1 Schraubsockel (E.8309.16)	Endoscope holder, complete, consisting of: 1 Telescope holder Ø 10 mm (E.8309.11) 1 Articulated stand 400 mm (E.8309.12) 1 Column, 500 mm, Ø 16 mm (E.8309.54) 1 Screw clamp base (E.8309.16)
E.8309.06	Endoskophalterung, komplett bestehend aus: 1 Universal Optikhalterung Ø 2 - 10 mm (E.8309.09) 1 Gelenkstativ 400 mm (E.8309.12) 1 Säule, 500 mm, Ø 16 mm (E.8309.54) 1 Schraubsockel (E.8309.16)	Endoscope holder, complete, consisting of: 1 Universal telescope holder Ø 2 - 10 mm (E.8309.09) 1 Articulated stand 400 mm (E.8309.12) 1 Column, 500 mm, Ø 16 mm (E.8309.54) 1 Screw clamp base (E.8309.16)
E.8309.04	Universal Wundhakenhalterung, komplett bestehend aus: 1 Universal Wundhakenhalterung (E.8309.07) 1 Gelenkstativ 400 mm (E.8309.12) 1 Säule, 500 mm, Ø 16 mm (E.8309.54) 1 Schraubsockel (E.8309.16)	Universal retractor holder, complete consisting of: 1 Universal retractor holder (E.8309.07) 1 Articulated stand 400 mm (E.8309.12) 1 Column, 500 mm, Ø 16 mm (E.8309.54) 1 Screw clamp base (E.8309.16)
E.8309.50	Doppelsystem-Endoskophalterung, kompl. bestehend aus: 1 Schraubsockel (E.8309.16) 1 Doppelarmsystem (E.8309.19) bestehend aus: 2 Gelenkstative 400 mm (E.8309.12) 1 Universal Optikhalterung Ø 2 - 10 mm (E.8309.09) 1 Säule, 500 mm, Ø 16 mm (E.8309.54) 1 Wundhakenhalterung (E.8309.07)	Double system endoscope holder, compl. consisting of: 1 Screw clamp base (E.8309.16) 1 Double system (E.8309.19) consisting of: 2 Articulated stand 400 mm (E.8309.12) 1 Universal telescope holder Ø 2 - 10 mm (E.8309.09) 1 Column, 500 mm, Ø 16 mm (E.8309.54) 1 Retractor holder (E.8309.07)

Andere Zusammenstellung der Sets auf Anfrage.
Other combinations of sets are available on request.

Innovation in der Laparoskopie
Innovation in laparoscopic surgery



Shedid Dissektor beleuchtet
nach Prof. Shedid
Shedid illuminated dissector
acc. to Prof. Shedid



S.0570.10

Ø 10 mm

Isolierter Dissektor mit integriertem Lichtleitkabel, 33 cm

1. Dissektion von Gewebe und Darmwänden bei gleichzeitiger Beleuchtung des Präparationsfeldes
2. HF-Anschluß ermöglicht eine Koagulation während der Präparation.
3. Der atraumatische Dissektor ist unentbehrlich für Darmresektionen durch die Beleuchtung des Dünndarmgekröses und erleichtert das Schneiden von blutarmen Gebieten.
4. In der Gynäkologie dient er zur Diagnose und der Beleuchtung der Tuben während dem Lösen von Verwachsungen.

Insulated dissector with integrated fibre optic light transmission, 33 cm

1. To simultaneously transilluminate and dissect through tissue layers and bowel walls.
2. HF connector provides the capability to coagulate tissue during dissection.
3. The blunt dissector is indispensable during bowel resection, as it can transilluminate the mesentery and facilitates cutting of avascular areas.
4. In Gynaecology, to explore and transilluminate the ovarian tube during adhesiolysis.

Fiberglas - Lichtleitkabel und Adapter Fibre optic light cable and adaptors



Fiberglas-Lichtleitkabel **ohne Adapter**
Fibre optic light cable **without adaptors**

E.8180.35	Ø 3,5 mm	180 cm
E.8230.35	Ø 3,5 mm	230 cm
E.8230.35X (Xenon)	Ø 3,5 mm	230 cm
E.8250.35	Ø 3,5 mm	250 cm
E.8300.35	Ø 3,5 mm	300 cm
E.8180.45	Ø 4,8 mm	180 cm
E.8230.45	Ø 4,8 mm	230 cm
E.8230.45X (Xenon)	Ø 4,8 mm	230 cm
E.8250.48	Ø 4,8 mm	250 cm
E.8300.48	Ø 4,8 mm	300 cm
E.8180.60	Ø 6,0 mm	180 cm
E.8230.60	Ø 6,0 mm	230 cm

Das Fiberglas-Lichtleitkabel mit Silicon-Kautschuk-Ummantelung ist auto-
klavierbar (134°C/2,3 bar), wasserdicht, weitgehend beständig gegen
Chemikalien und Lösungsmittel, zugentlastet und sehr flexibel.

Überlängen und Sonderwünsche auf Anfrage.

The flexible fibre optic light cable with silicon encasing is autoclavable
(134°C/2.3 bar), waterproof, particularly resistant to chemical solutions,
and load tension.

Special length and special requirements on request.



Fluid-Lichtkabel, **einlegbar**, inkl. GIMMI/Storz Lichtquellen-Adapter
Fluid light cable, **soakable**, incl. GIMMI/Storz light source adaptor

E.8230.50F	Ø 5,0 mm	230 cm
-------------------	----------	--------









Adapter für Fluid-Lichtkabel – Wolf/HSW Lichtquelle
Adaptor for fluid light cable – Wolf/HSW light source

E.8002.01

Adapter für Fluid-Lichtkabel – Olympus Lichtquelle
Adaptor for fluid light cable – Olympus light source

E.8006.09

Die Adapter "Instrumentenseite" bitte aus der folgenden Aufstellung auswählen.
Please select the adaptors "Instrument End" from the following list

Kabel Ø Cable Ø	Adapter Nr. Adaptor No.	Lichtquellen-Seite Light source end	Instrumentenseite Instrument end	Adapter Nr. Adaptor No.
3,5/4,8 mm	E.8000.01 GIMMI/STORZ			E.8001.02
6,0 mm	E.8000.06 GIMMI/STORZ			E.8001.04
3,5/4,8 mm	E.8002.03 WOLF/HSW			E.8002.04
6,0 mm	E.8002.06 WOLF/HSW			E.8002.07
3,5/4,8 mm	E.8003.05 ACMI/Stryker			E.8003.06
6,0 mm	E.8003.09 ACMI/Stryker			E.8003.07
3,5/4,8 mm	E.8006.11 OLYMPUS			
3,5/4,8 mm	E.8008.15 VOLPI			

Trokar mit Silikonventil und Hahn zur Insufflation Trocar with silicone valve and stopcock for insufflation



"light line"

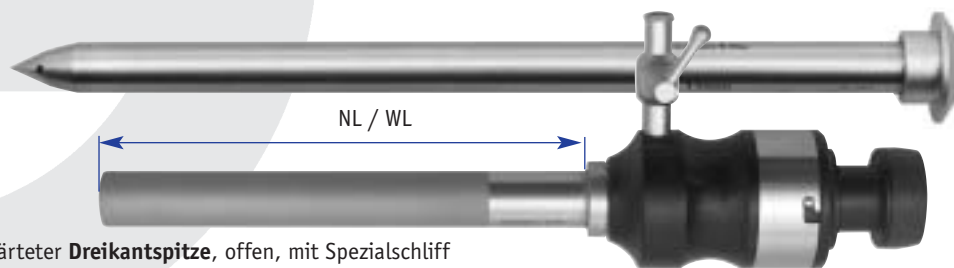

Trokarhülse mit Trokardorn mit gehärteter **Dreikantspitze**, offen, mit Spezialschliff
Trocar sleeve with trocar mandrin with hardened **pyramidal tip**, open, special cut

Trokar komplett Trocar complete	Trokarhülse allein Trocar sleeve only	Durchmesser Diameter	Nutzlänge Working length
T.8002.03	T.8004.03	Ø 3,5 mm	70 mm
T.8002.05	T.8004.05	Ø 5,0 mm	92 mm
T.8002.06	T.8004.06	Ø 5,5 mm	95 mm
T.8002.08	T.8004.08	Ø 8,0 mm	105 mm
T.8002.10	T.8004.10	Ø 10,0 mm	97 mm
T.8002.11	T.8004.11	Ø 11,0 mm	101 mm
T.8002.12	T.8004.12	Ø 12,5 mm	98 mm
T.8002.13	T.8004.13	Ø 13,0 mm	98 mm

"light line"

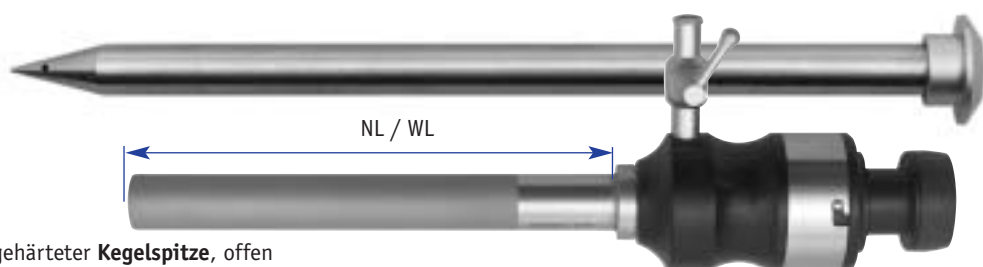

Trokarhülse mit Trokardorn mit gehärteter **Kegelspitze**, offen
Trocar sleeve with trocar mandrin with hardened **cone-shaped tip**, open

Trokar komplett Trocar complete	Trokarhülse allein Trocar sleeve only	Durchmesser Diameter	Nutzlänge Working length
T.8003.03	T.8004.03	Ø 3,5 mm	70 mm
T.8003.05	T.8004.05	Ø 5,0 mm	92 mm
T.8003.06	T.8004.06	Ø 5,5 mm	95 mm
T.8003.08	T.8004.08	Ø 8,0 mm	105 mm
T.8003.10	T.8004.10	Ø 10,0 mm	97 mm
T.8003.11	T.8004.11	Ø 11,0 mm	101 mm
T.8003.12	T.8004.12	Ø 12,5 mm	98 mm
T.8003.13	T.8004.13	Ø 13,0 mm	98 mm

Ersatz-Silikonventil für T.8004.03 - T.8004.13, Pack à 5 Stück
Spare silicone valve for T.8004.03 - T.8004.13, box of 5 ea.

	Für Trokarhülse For trocar sleeve
T.8004.36	Ø 3,5 - 8,0
T.8004.42	Ø 10,0 - 13,0

Die auf Seite 18 bis 20 abgebildeten Trokardorne können ebenfalls verwendet werden.
The trocar mandrins illustrated on page 18 till 20 can also be used.

Trokar mit Silikonventil und Hahn zur Insufflation Trocar with silicone valve and stopcock for insufflation



Trokarhülle mit Trokardorn mit gehärteter **Dreikantspitze**, offen, mit Spezialschliff
Trocar sleeve with trocar mandrin with hardened **pyramidal tip**, open, special cut

Trokar komplett Trocar complete	Trokarhülle allein Trocar sleeves only	Durchmesser Diameter	Nutzlänge Working length
T.8052.05	T.8051.05	Ø 5,0 mm	92 mm
T.8052.06	T.8051.06	Ø 5,5 mm	95 mm
T.8052.08	T.8051.08	Ø 8,0 mm	105 mm
T.8052.10	T.8051.10	Ø 10,0 mm	97 mm
T.8052.11	T.8051.11	Ø 11,0 mm	101 mm
T.8052.12	T.8051.12	Ø 12,5 mm	98 mm

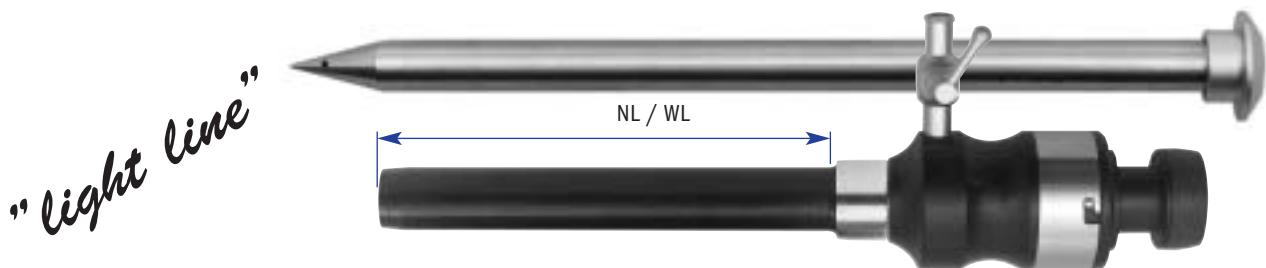

Trokarhülle mit Trokardorn mit gehärteter **Kegelspitze**, offen
Trocar sleeve with trocar mandrin with hardened **cone-shaped tip**, open

Trokar komplett Trocar complete	Trokarhülle allein Trocar sleeves only	Durchmesser Diameter	Nutzlänge Working length
T.8053.05	T.8051.05	Ø 5,0 mm	92 mm
T.8053.06	T.8051.06	Ø 5,5 mm	95 mm
T.8053.08	T.8051.08	Ø 8,0 mm	105 mm
T.8053.10	T.8051.10	Ø 10,0 mm	97 mm
T.8053.11	T.8051.11	Ø 11,0 mm	101 mm
T.8053.12	T.8051.12	Ø 12,5 mm	98 mm

Ersatz-Silikonventil für T.8051.05 - T.8051.12, Pack à 5 Stück
Spare silicone valve for T.8051.05 - T.8051.12, box of 5 ea.

	Für Trokarhülle For trocar sleeve
T.8004.36	Ø 3,5 - 8,0
T.8004.42	Ø 10,0 - 13,0

Die auf Seite 18 bis 20 abgebildeten Trokardorne können ebenfalls verwendet werden.
The trocar mandrins illustrated on page 18 till 20 can also be used.

Trocar mit Silikonventil und Hahn zur Insufflation Trocar with silicone valve and stopcock for insufflation



"light line"

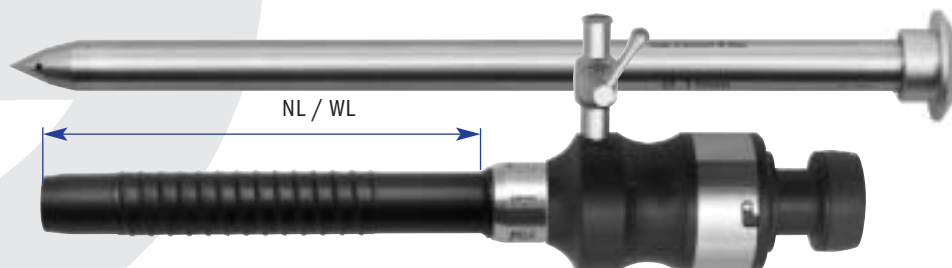

Trocarhülse mit Trocardorn mit gehärteter **Dreikantspitze**, offen, mit Spezialschliff
Trocar sleeve with trocar mandrin with hardened **pyramidal tip**, open, special cut

Trocar komplett Trocar complete	Trocarhülse allein Trocar sleeve only	Durchmesser Diameter	Nutzlänge Working length
T.8056.05	T.8055.05	Ø 5,0 mm	92 mm
T.8056.06	T.8055.06	Ø 5,5 mm	95 mm
T.8056.08	T.8055.08	Ø 8,0 mm	105 mm
T.8056.10	T.8055.10	Ø 10,0 mm	97 mm
T.8056.11	T.8055.11	Ø 11,0 mm	101 mm
T.8056.12	T.8055.12	Ø 12,5 mm	98 mm

"light line"

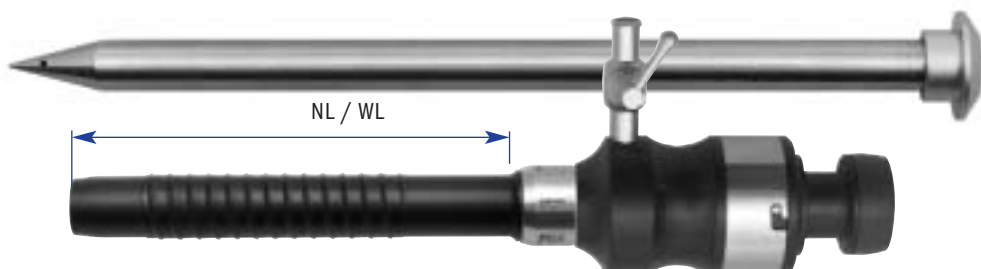

Trocarhülse mit Trocardorn mit gehärteter **Kegelspitze**, offen
Trocar sleeve with trocar mandrin with hardened **cone-shaped tip**, open

Trocar komplett Trocar complete	Trocarhülse allein Trocar sleeve only	Durchmesser Diameter	Nutzlänge Working length
T.8057.05	T.8055.05	Ø 5,0 mm	92 mm
T.8057.06	T.8055.06	Ø 5,5 mm	95 mm
T.8057.08	T.8055.08	Ø 8,0 mm	105 mm
T.8057.10	T.8055.10	Ø 10,0 mm	97 mm
T.8057.11	T.8055.11	Ø 11,0 mm	101 mm
T.8057.12	T.8055.12	Ø 12,5 mm	98 mm

Ersatz-Silikonventil für T.8055.05 - T.8055.12, Pack à 5 Stück
Spare silicone valve for T.8055.05 - T.8055.12, box of 5 ea.

	Für Trocarhülse For trocar sleeve
T.8004.36	Ø 3,5 - 8,0
T.8004.42	Ø 10,0 - 13,0

Die auf Seite 19 bis 20 abgebildeten Trocardorne können ebenfalls verwendet werden.
The trocar mandrins illustrated on page 18 till 20 can also be used.

Trokare und Zubehör Trocars and accessories



Automatiktrokarhülse mit Hahn zur Insufflation und Trokardorn mit **Dreikantspitze**

Automatic trocar sleeve with stopcock for insufflation and trocar mandrin with **pyramidal** tip

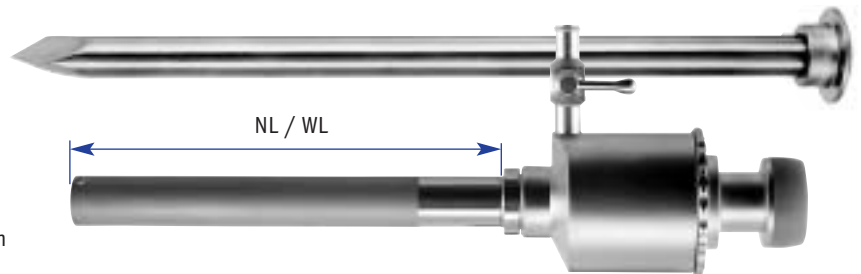

Trokar komplett Trocar complete	Trokarhülse allein Trocar sleeve only	Trokardorn allein Trocar mandrin only	Durchmesser Diameter	Nutzlänge Working length
T.8013.03	T.8012.24	T.8010.42	Ø 3,5 mm	70 mm
T.8013.05	T.8012.25	T.8010.45	Ø 5,0 mm	92 mm
T.8013.06	T.8012.26	T.8010.46	Ø 5,5 mm	95 mm
T.8013.09	T.8012.29	T.8010.49	Ø 6,0 mm	105 mm
T.8013.14	T.8012.34	T.8010.54	Ø 6,5 mm	97 mm
T.8013.07	T.8012.27	T.8010.47	Ø 7,0 mm	101 mm
T.8013.08	T.8012.28	T.8010.48	Ø 8,0 mm	98 mm
T.8013.10	T.8012.30	T.8010.50	Ø 10,0 mm	97 mm
T.8013.11	T.8012.31	T.8010.51	Ø 11,0 mm	101 mm
T.8013.12	T.8012.32	T.8010.52	Ø 12,5 mm	98 mm

Automatiktrokarhülse mit Hahn zur Insufflation und Trokardorn mit **Kegelspitze**

Automatic trocar sleeve with stopcock for insufflation and trocar mandrin with **cone-shaped** tip

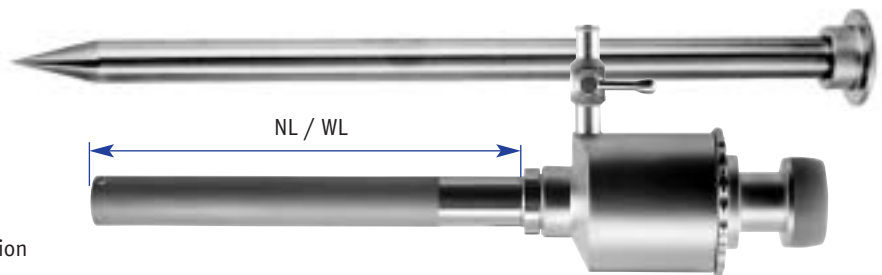

Trokar komplett Trocar complete	Trokarhülse allein Trocar sleeve only	Trokardorn allein Trocar mandrin only	Durchmesser Diameter	Nutzlänge Working length
T.8012.03	T.8012.24	T.8011.42	Ø 3,0 mm	70 mm
T.8012.05	T.8012.25	T.8011.45	Ø 5,0 mm	92 mm
T.8012.06	T.8012.26	T.8011.46	Ø 5,5 mm	95 mm
T.8012.09	T.8012.29	T.8011.49	Ø 6,0 mm	95 mm
T.8012.14	T.8012.34	T.8011.54	Ø 6,5 mm	95 mm
T.8012.07	T.8012.27	T.8011.47	Ø 7,0 mm	95 mm
T.8012.08	T.8012.28	T.8011.48	Ø 8,0 mm	105 mm
T.8012.10	T.8012.30	T.8011.50	Ø 10,0 mm	97 mm
T.8012.11	T.8012.31	T.8011.51	Ø 11,0 mm	101 mm
T.8012.12	T.8012.32	T.8011.52	Ø 12,5 mm	98 mm



Trokare und Zubehör Trocars and accessories

Mehrfachfunktion - Trokarhülse mit manueller Klappenöffnung, Hahn zur Insufflation und Trokardorn mit **Dreikantspitze**

Multiple function trocar sleeve with manual opening lever, stopcock for insufflation and trocar mandrin with **pyramidal tip**

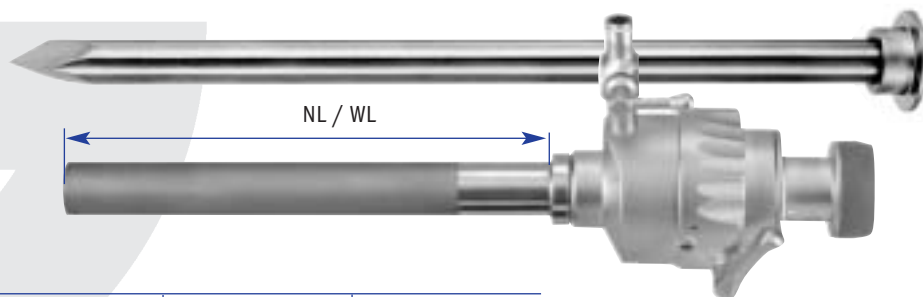

Trokar komplett Trocar complete	Trokarhülse allein Trocar sleeve only	Trokardorn allein Trocar mandrin only	Durchmesser Diameter	Nutzlänge Working length
T.8017.23	T.8017.03	T.8010.42	Ø 3,5 mm	70 mm
T.8017.25	T.8017.05	T.8010.45	Ø 5,0 mm	92 mm
T.8017.26	T.8017.15	T.8010.46	Ø 5,5 mm	95 mm
T.8017.36	T.8017.16	T.8010.49	Ø 6,0 mm	95 mm
T.8017.37	T.8017.17	T.8010.54	Ø 6,5 mm	95 mm
T.8017.27	T.8017.07	T.8010.47	Ø 7,0 mm	95 mm
T.8017.28	T.8017.08	T.8010.48	Ø 8,0 mm	105 mm
T.8017.30	T.8017.10	T.8010.50	Ø 10,0 mm	97 mm
T.8017.31	T.8017.11	T.8010.51	Ø 11,0 mm	101 mm
T.8017.32	T.8017.12	T.8010.52	Ø 12,5 mm	98 mm
T.8017.33	T.8017.18	T.8010.56	Ø 13,0 mm	97 mm
* T.8017.34	T.8017.19	T.8010.55	Ø 15,0 mm	95 mm
* T.8017.35	T.8017.20	T.8010.60	Ø 20,0 mm	95 mm

*Trokarhülse mit schrägem distalen Ende

*Trocar sleeve with oblique distal tip

Mehrfachfunktion - Trokarhülse mit manueller Klappenöffnung, Hahn zur Insufflation und Trokardorn mit **Kegelspitze**

Multiple function trocar sleeve with manual opening lever, stopcock for insufflation and trocar mandrin with **cone-shaped tip**

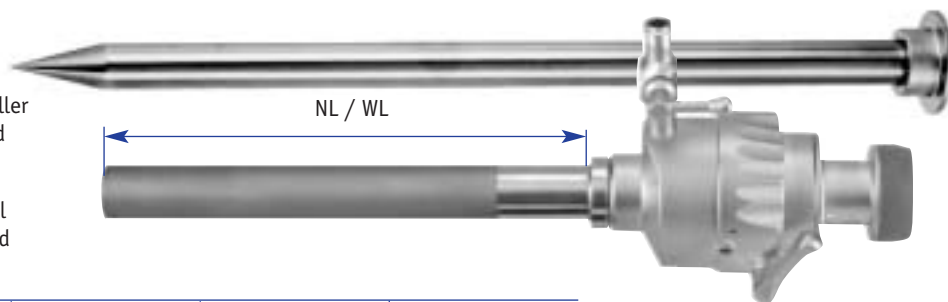

Trokar komplett Trocar complete	Trokarhülse allein Trocar sleeve only	Trokardorn allein Trocar mandrin only	Durchmesser Diameter	Nutzlänge Working length
T.8017.43	T.8017.03	T.8011.42	Ø 3,5 mm	70 mm
T.8017.45	T.8017.05	T.8011.45	Ø 5,0 mm	92 mm
T.8017.46	T.8017.15	T.8011.46	Ø 5,5 mm	95 mm
T.8017.56	T.8017.16	T.8011.49	Ø 6,0 mm	95 mm
T.8017.57	T.8017.17	T.8011.54	Ø 6,5 mm	95 mm
T.8017.47	T.8017.07	T.8011.47	Ø 7,0 mm	95 mm
T.8017.48	T.8017.08	T.8011.48	Ø 8,0 mm	105 mm
T.8017.50	T.8017.10	T.8011.50	Ø 10,0 mm	97 mm
T.8017.51	T.8017.11	T.8011.51	Ø 11,0 mm	101 mm
T.8017.52	T.8017.12	T.8011.52	Ø 12,5 mm	98 mm
T.8017.53	T.8017.18	T.8011.56	Ø 13,0 mm	97 mm
* T.8017.54	T.8017.19	T.8011.55	Ø 15,0 mm	95 mm
* T.8017.55	T.8017.20	T.8011.60	Ø 20,0 mm	95 mm

*Trokarhülse mit schrägem distalen Ende

*Trocar sleeve with oblique distal tip

Trokare und Zubehör Trocar and accessories



Trocarhülse mit Trompetenventil,
Hahn zur Insufflation und Trocardorn
mit **Dreikantspitze**

Trocar sleeve with trumpet valve,
stopcock for insufflation and trocar
mandrin with **pyramidal** tip

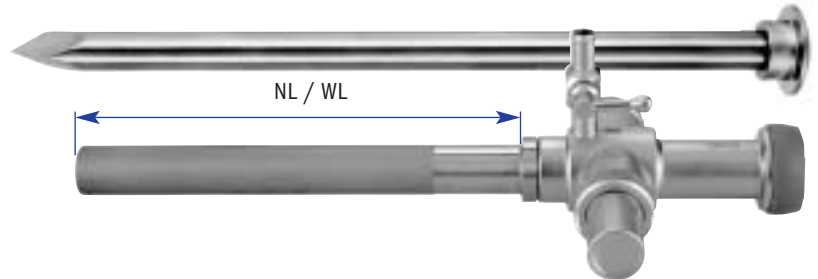

Trocar komplett Trocar complete	Trocarhülse allein Trocar sleeve only	Trocardorn allein Trocar mandrin only	Durchmesser Diameter	Nutzlänge Working length
T.8010.03	T.8010.23	T.8010.43	Ø 3,0 mm	40 mm
T.8010.04	T.8010.24	T.8010.44	Ø 3,0 mm	105 mm
T.8010.05	T.8010.25	T.8010.45	Ø 5,0 mm	107 mm
T.8010.06	T.8010.26	T.8010.46	Ø 5,5 mm	110 mm
T.8010.08	T.8010.28	T.8010.48	Ø 8,0 mm	104 mm
T.8010.10	T.8010.30	T.8010.50	Ø 10,0 mm	101 mm
T.8010.11	T.8010.31	T.8010.51	Ø 11,0 mm	105 mm
T.8010.12	T.8010.32	T.8010.52	Ø 12,5 mm	105 mm
T.8010.15	T.8010.35	T.8010.55	Ø 15,0 mm	96 mm
T.8010.20	T.8010.40	T.8010.60	Ø 20,0 mm	96 mm

Trocarhülse mit Trompetenventil,
Hahn zur Insufflation und Trocardorn
mit **Kegelschliff**

Trocar sleeve with trumpet valve,
stopcock for insufflation and trocar
mandrin with **cone-shaped** tip

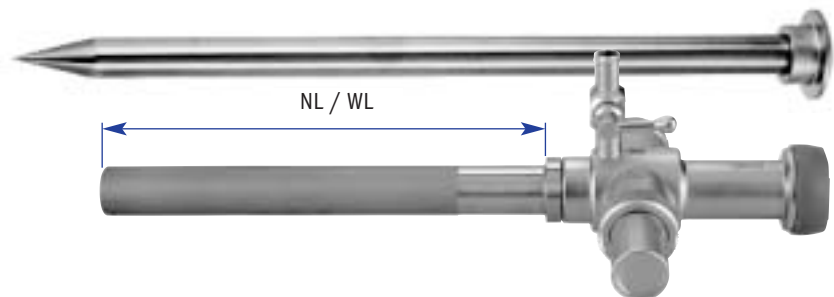

Trocar komplett Trocar complete	Trocarhülse allein Trocar sleeve only	Trocardorn allein Trocar mandrin only	Durchmesser Diameter	Nutzlänge Working length
T.8011.03	T.8010.23	T.8011.43	Ø 3,0 mm	40 mm
T.8011.04	T.8010.24	T.8011.44	Ø 3,0 mm	105 mm
T.8011.05	T.8010.25	T.8011.45	Ø 5,0 mm	107 mm
T.8011.06	T.8010.26	T.8011.46	Ø 5,5 mm	110 mm
T.8011.08	T.8010.28	T.8011.48	Ø 8,0 mm	104 mm
T.8011.10	T.8010.30	T.8011.50	Ø 10,0 mm	101 mm
T.8011.11	T.8010.31	T.8011.51	Ø 11,0 mm	105 mm
T.8011.12	T.8010.32	T.8011.52	Ø 12,5 mm	105 mm
T.8011.15	T.8010.35	T.8011.55	Ø 15,0 mm	96 mm
T.8011.20	T.8010.40	T.8011.60	Ø 20,0 mm	96 mm

HASSON Trokare und Zubehör HASSON trocars and accessories



HASSON Trokar mit Trompetenventil,
mit Fadeneinhängung, Hahn zur Insufflation
und Trokardorn mit stumpfer Spitze

HASSON trocar **with suture holder**,
trumpet valve, stopcock for insufflation
and trocar mandrin with blunt tip



T.8014.10	10,0 mm
T.8014.11	11,0 mm

HASSON Trokar **mit Fadeneinhängung am Konus**,
mit Trompetenventil, Hahn zur Insufflation
und Trokardorn mit stumpfer Spitze

HASSON trocar **with suture holder fixed at cone**,
trumpet valve, stopcock for insufflation
and trocar mandrin with blunt tip

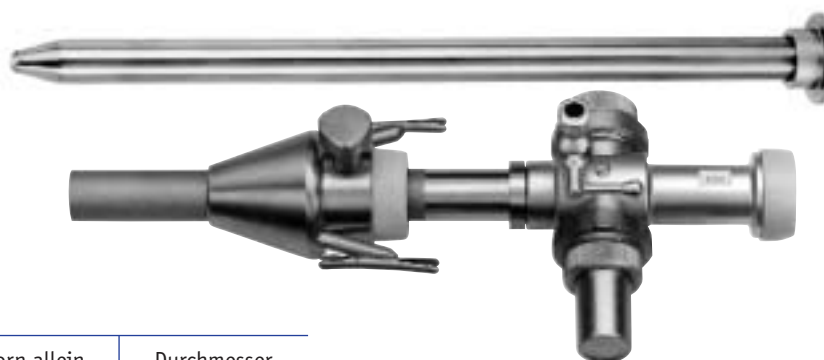

Trokar komplett Trocar complete	Hülse mit Konus allein Sleeve with cone only	Trokardorn allein Trocar mandrin only	Durchmesser Diameter
T.8014.15	T.8014.25	T.8014.65	Ø 5,0 mm
T.8014.16	T.8014.26	T.8014.66	Ø 5,5 mm
T.8014.20	T.8014.30	T.8014.70	Ø 10,0 mm
T.8014.21	T.8014.31	T.8014.71	Ø 11,0 mm

HASSON Trokare und Zubehör HASSON trocars and accessories



HASSON Automatiktrokar
mit Fadeneinhängung am Konus,
Hahn zur Insufflation und Trokardorn
mit stumpfer Spitze

HASSON automatic trocar
with suture holder fixed at cone,
trumpet valve, stopcock for insufflation
and trocar mandrin with blunt tip

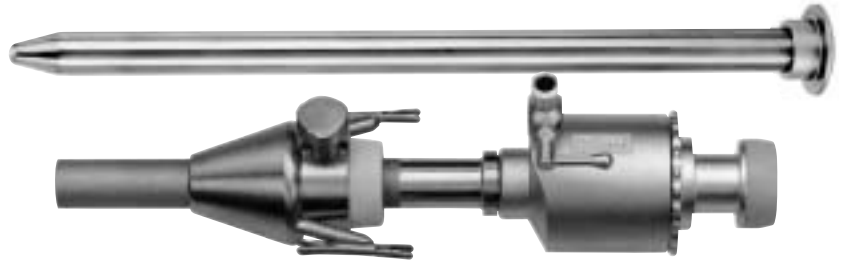

Trokar komplett Trocar complete	Hülse mit Konus allein Sleeve with cone only	Trokardorn allein Trocar mandrin only	Durchmesser Diameter
T.8014.33	T.8014.43	T.8014.63	Ø 3,5 mm
T.8014.35	T.8014.45	T.8014.65	Ø 5,0 mm
T.8014.36	T.8014.46	T.8014.66	Ø 5,5 mm
T.8014.40	T.8014.50	T.8014.70	Ø 10,0 mm
T.8014.41	T.8014.51	T.8014.71	Ø 11,0 mm

Fixierbarer Konus allein, für HASSON Trokar, **mit Fadeneinhängung,** passend zu allen Trokarhülsen
Fixation cone only, for HASSON trocar, **with suture holder,** fits all trocar sleeves

T.8014.83	Ø 3,5 mm
T.8014.85	Ø 5,0 mm
T.8014.86	Ø 5,5 mm
T.8014.90	Ø 10,0 mm
T.8014.91	Ø 11,0 mm
T.8014.92	Ø 12,5 mm

in Zusammenhang mit einer
Kunststoff-Trokarhülse von GIMMI
bestellen Sie bitte den Konus mit
dem nächst größeren Durchmesser
(11 mm ⇒ 12,5 mm)

in combination with a GIMMI plastic
trocar sleeve, please order the cone
one size larger (11 mm ⇒ 12,5 mm)



Fixierbarer Konus mit Gewinde
für HASSON Trokar, passend zu 10 mm Kunststoff- und
11 mm Stahl-Trokarhülsen, **ohne Fadeneinhängung**

Fixation cone with thread
for HASSON trocar, fits 10 mm plastic- and
11 mm steel trocar sleeves, **without suture holder**

T.8014.94	Ø 11,0 mm
------------------	-----------



Thorakoskopie Trokare Thoracic trocars



Starre Thorakoskopie Trokare
Thoracic trocars rigid

Hülse mit Trokar Sleeve with trocar	Trokarhülse allein Trocar sleeve only	Trokardorn allein Trocar mandrin only	Nutzlänge Working length	Durchmesser Diameter
T.8026.06	T.8026.26	T.8026.36	50 mm	Ø 6,0 mm
T.8026.11	T.8026.21	T.8026.31	50 mm	Ø 11,0 mm
T.8026.13	T.8026.23	T.8026.33	50 mm	Ø 13,0 mm



Flexible Thorakoskopie Trokare
Thoracic trocars flexible

Flexible Kunststoffrohre Pack mit 5 Stck.
Flexible plastic tubes box of 5 ea.

Hülse mit Trokar Sleeve with trocar	Trokarhülse allein Trocar sleeve only	Trokardorn allein Trocar mandrin only	Kunststoffrohre allein Plastic tubes only	Nutzlänge Working length	Durchmesser Diameter
T.8027.06	T.8027.26	T.8027.36	T.8027.46	100 mm	Ø 6,0 mm
T.8027.07	T.8027.27	T.8027.37	T.8027.47	70 mm	Ø 6,0 mm
T.8027.11	T.8027.21	T.8027.31	T.8027.41	100 mm	Ø 11,0 mm
T.8027.12	T.8027.22	T.8027.32	T.8027.42	70 mm	Ø 11,0 mm

Trokarhülse ohne Ventile **für die gaslose Endoskopie**
komplett mit Trokardorn mit Dreikant- **oder** Kegelspitze

Trocar sleeves without valves **for gasless Endoscopy**
complete with trocar mandrin with pyramidal **or** cone-shaped tip

Mit Dreikanttrocakr With pyramidal trocar	Mit Kegelform Trokar With cone-shaped trocar	Durchmesser Diameter
T.8021.05	T.8021.25	Ø 5,0 mm
T.8021.06	T.8021.26	Ø 5,5 mm
T.8021.10	T.8021.30	Ø 10,0 mm
T.8021.11	T.8021.31	Ø 11,0 mm
T.8021.12	T.8021.32	Ø 12,5 mm



Trokare und Zubehör Trocars and accessories



Trokardorn mit gehärteter Dreikantspitze, offen, mit Spezialschliff
Trocar mandrin with hardened pyramidal tip, open, special cut

	Durchmesser Diameter	Nutzlänge Working length
T.8005.05	Ø 5,0 mm	166 mm
T.8005.06	Ø 5,5 mm	170 mm
T.8005.08	Ø 8,0 mm	185 mm
T.8005.10	Ø 10,0 mm	183 mm
T.8005.11	Ø 11,0 mm	189 mm
T.8005.12	Ø 12,5 mm	191 mm
T.8005.13	Ø 13,0 mm	191 mm

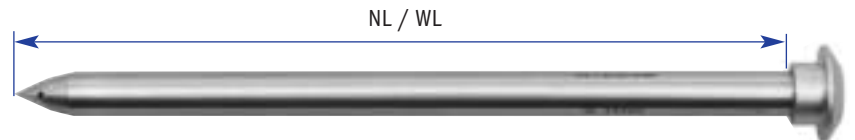

Trokardorn mit gehärteter Kegelspitze, offen
Trocar mandrin with hardened cone-shaped tip, open

	Durchmesser Diameter	Nutzlänge Working length
T.8006.05	Ø 5,0 mm	168 mm
T.8006.06	Ø 5,5 mm	172 mm
T.8006.08	Ø 8,0 mm	187 mm
T.8006.10	Ø 10,0 mm	188 mm
T.8006.11	Ø 11,0 mm	193 mm
T.8006.12	Ø 12,5 mm	193 mm
T.8006.13	Ø 13,0 mm	193 mm



Trokardorn mit Dreikantspitze
Trocar mandrin with pyramidal tip

	Durchmesser Diameter	Nutzlänge Working length
T.8010.43	Ø 3,0 mm	82 mm
T.8010.44	Ø 3,0 mm	146 mm
T.8010.42	Ø 3,5 mm	132 mm
T.8010.45	Ø 5,0 mm	166 mm
T.8010.46	Ø 5,5 mm	170 mm
T.8010.49	Ø 6,0 mm	176 mm
T.8010.54	Ø 6,5 mm	173 mm
T.8010.47	Ø 7,0 mm	174 mm
T.8010.48	Ø 8,0 mm	185 mm
T.8010.50	Ø 10,0 mm	183 mm
T.8010.53	Ø 10,5 mm	188 mm
T.8010.51	Ø 11,0 mm	189 mm
T.8010.52	Ø 12,5 mm	191 mm
T.8010.56	Ø 13,0 mm	195 mm
T.8010.55	Ø 15,0 mm	203 mm
T.8010.60	Ø 20,0 mm	221 mm

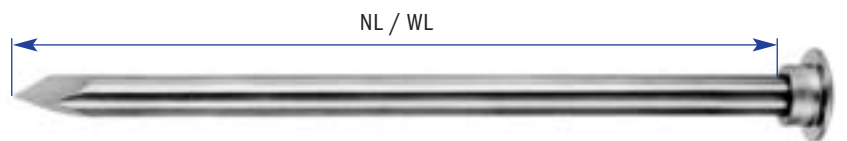

Trokare und Zubehör Trocars and accessories



Trokardorn mit Kegelspitze
Trocar mandrin with cone-shaped tip

	Durchmesser Diameter	Nutzlänge Working length
T.8011.43	Ø 3,0 mm	83 mm
T.8011.44	Ø 3,0 mm	147 mm
T.8011.42	Ø 3,5 mm	134 mm
T.8011.45	Ø 5,0 mm	168 mm
T.8011.46	Ø 5,5 mm	172 mm
T.8011.49	Ø 6,0 mm	175 mm
T.8011.54	Ø 6,5 mm	176 mm
T.8011.47	Ø 7,0 mm	176 mm
T.8011.48	Ø 8,0 mm	187 mm
T.8011.50	Ø 10,0 mm	188 mm
T.8011.53	Ø 10,5 mm	192 mm
T.8011.51	Ø 11,0 mm	193 mm
T.8011.52	Ø 12,5 mm	193 mm
T.8011.56	Ø 13,0 mm	195 mm
T.8011.55	Ø 15,0 mm	203 mm
T.8011.60	Ø 20,0 mm	219 mm

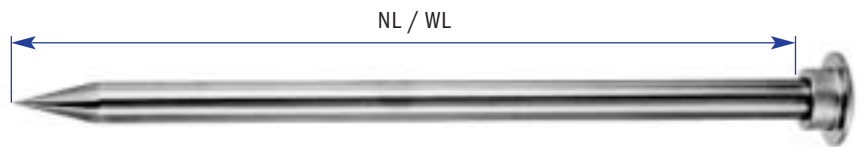

Sicherheitstrokardorn mit Dreikantspitze (demontierbar), verwendbar mit allen Trocarhülsen
Secure trocar mandrin with pyramidal tip (detachable), fits all trocar sleeves

	Durchmesser Diameter	Nutzlänge Working length
T.8018.05	Ø 5,0 mm	157 mm
T.8018.06	Ø 5,5 mm	160 mm
T.8018.08	Ø 8,0 mm	171 mm
T.8018.10	Ø 10,0 mm	167 mm
T.8018.11	Ø 11,0 mm	171 mm
T.8018.12	Ø 12,5 mm	171 mm

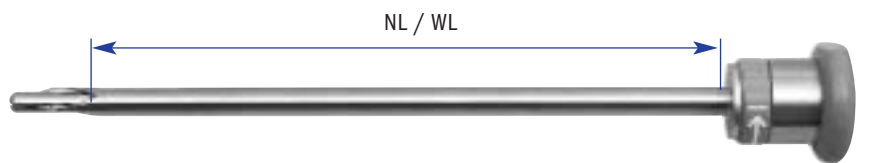

Sicherheitstrokardorn mit schräger Spitze (demontierbar), verwendbar mit allen Trocarhülsen
Secure trocar with oblique tip (detachable), fits all trocar sleeves

	Durchmesser Diameter	Nutzlänge Working length
T.8016.05	Ø 5,0 mm	157 mm
T.8016.06	Ø 5,5 mm	160 mm
T.8016.08	Ø 8,0 mm	171 mm
T.8016.10	Ø 10,0 mm	167 mm
T.8016.11	Ø 11,0 mm	171 mm
T.8016.12	Ø 12,5 mm	171 mm

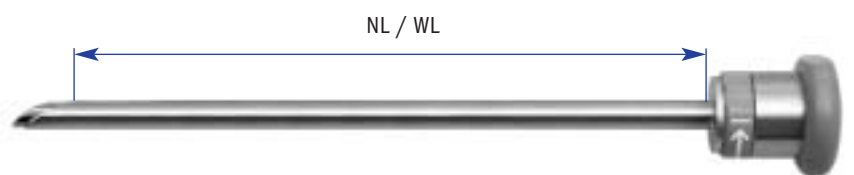

Trokare und Zubehör Trocar and accessories



Schutztrokardorn, stumpf, (demontierbar) verwendbar mit allen Trokarhülsen
Protection trocar mandrin, blunt, (detachable) fits all trocar sleeves

	Durchmesser Diameter	Nutzlänge Working length
T.8019.05	Ø 5,0 mm	157 mm
T.8019.06	Ø 5,5 mm	160 mm
T.8019.08	Ø 8,0 mm	171 mm
T.8019.10	Ø 10,0 mm	167 mm
T.8019.11	Ø 11,0 mm	171 mm
T.8019.12	Ø 12,5 mm	171 mm



Schutztrokardorn mit schräger Spitze (demontierbar), verwendbar mit allen Trokarhülsen
Protection trocar mandrin with oblique tip (detachable), fits all trocar sleeves

	Durchmesser Diameter	Nutzlänge Working length
T.8020.05	Ø 5,0 mm	157 mm
T.8020.06	Ø 5,5 mm	160 mm
T.8020.08	Ø 8,0 mm	171 mm
T.8020.10	Ø 10,0 mm	167 mm
T.8020.11	Ø 11,0 mm	171 mm
T.8020.12	Ø 12,5 mm	171 mm

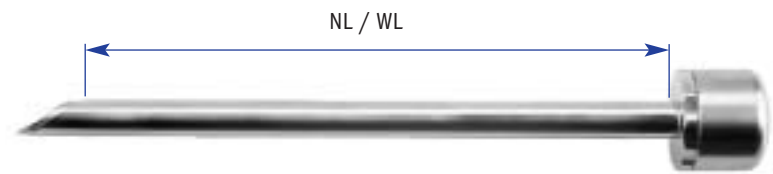

Zubehör für Trokare Accessories for trocars



Trokarrohre, auswechselbar, für Trokare mit Trompetenventil
Trocar sleeves, interchangeable, for trocars with trumpet-valve

	Für Durchm. Trokarhülse For diam. trocar sleeve	Nutzlänge Working length
T.8023.28	Ø 3,0 mm	40 mm
T.8023.30	Ø 3,0 mm	105 mm
T.8023.00	Ø 5,0 mm	107 mm
T.8023.01	Ø 5,5 mm	110 mm
T.8023.32	Ø 8,0 mm	104 mm
T.8023.02	Ø 10,0 mm	101 mm
T.8023.03	Ø 11,0 mm	105 mm
T.8023.04	Ø 12,5 mm	105 mm
T.8023.40	Ø 15,0 mm	96 mm
T.8023.42	Ø 20,0 mm	96 mm



Trokarrohre, auswechselbar, für Automatiktrokare
Trocar sleeves, interchangeable, for automatic trocars

Rohr glatt Tube smooth	Für Durchm. Trokarhülse For diam. trocar sleeve	Nutzlänge Working length
T.8023.35	Ø 3,5 mm	70 mm
T.8023.05	Ø 5,0 mm	92 mm
T.8023.06	Ø 5,5 mm	95 mm
T.8023.08	Ø 8,0 mm	105 mm
T.8023.10	Ø 10,0 mm	97 mm
T.8023.11	Ø 11,0 mm	101 mm
T.8023.12	Ø 12,5 mm	98 mm
T.8023.44	Ø 13,0 mm	97 mm
T.8023.46	Ø 15,0 mm	95 mm
T.8023.48	Ø 20,0 mm	95 mm



Trokarrohre, auswechselbar aus Kunststoff, für Automatiktrokare
Trocar sleeves, interchangeable, plastic, for automatic trocars

Rohr glatt Tube smooth	Rohr mit Gewinde Tube with thread	Für Durchm. Trokarhülse For diam. trocar sleeve	Nutzlänge Working length
T.8042.00	T.8044.00	Ø 5,0 mm	92 mm
T.8042.02	T.8044.02	Ø 5,5 mm	95 mm
T.8042.04	T.8044.04	Ø 8,0 mm	105 mm
T.8042.06	T.8044.06	Ø 10,0 mm	97 mm
T.8042.08	T.8044.08	Ø 11,0 mm	101 mm
T.8042.10	T.8044.10	Ø 12,5 mm	98 mm



Zubehör für Trokare Accessories for trocars



Trokarstop für Trokarhülsen
Trocar stop for trocar sleeves

	Gewindelänge Length of thread	Für Durchm. Trokarhülse For diam. trocar sleeves
T.8022.05	20 mm	Ø 5,0 mm
T.8022.15	50 mm	
T.8022.06	20 mm	Ø 5,5 mm
T.8022.16	50 mm	
T.8022.10	20 mm	Ø 10,0 mm
T.8022.20	50 mm	
T.8022.11	20 mm	Ø 11,0 mm
T.8022.21	50 mm	
T.8022.12	20 mm	Ø 12,5 mm
T.8022.22	50 mm	



Reduzierhülsen
Reducer sleeves



	Durchm. Trokarhülse Diam. trocar sleeve	Durchm. Instrument Diam. instrument	Nutzlänge Working length
T.1106.05	Ø 5,5 mm	Ø 3,0 mm	190 mm
T.1106.06	Ø 10,0 mm	Ø 5,5 mm	190 mm
T.1106.10	Ø 11,0 mm	Ø 5,5 mm	190 mm
T.1106.12	Ø 12,5 mm	Ø 5,5 mm	190 mm
T.1106.13	Ø 12,5 mm	Ø 10,0 mm	190 mm
T.1106.14	Ø 15,0 mm	Ø 5,5 mm	190 mm
T.1106.15	Ø 15,0 mm	Ø 10,0 mm	190 mm
T.1106.16	Ø 15,0 mm	Ø 11,0 mm	190 mm
T.1106.17	Ø 20,0 mm	Ø 5,5 mm	190 mm
T.1106.20	Ø 20,0 mm	Ø 10,0 mm	190 mm
T.1106.21	Ø 20,0 mm	Ø 11,0 mm	190 mm
T.1106.22	Ø 20,0 mm	Ø 15,0 mm	190 mm

Zubehör für Trokare Accessories for trocars



Reduzieraufsatz (verwendbar für alle Trokarhülsen, außer Trokarhülsen mit Trompetenventil)
Reducer (fits all trocar sleeves, except those with trumpet valve)

	Durchm. Trokarhülse Diam. trocar sleeve	Durchm. Instrument Diam. instrument
T.8024.09	Ø 5,5 mm	Ø 3,0 mm
T.8024.10	Ø 10,0 mm	Ø 5,5 mm
T.8024.20	Ø 11,0 mm	Ø 5,5 mm
T.8024.21	Ø 12,5 mm	Ø 5,5 mm
T.8024.22	Ø 12,5 mm	Ø 10,0 mm
T.8024.23	Ø 13,0 mm	Ø 5,5 mm



Reduzieraufsatz, abnehmbar, mit Silikonhalterung
Reducer, removable, with silicone holder

	Durchm. Trokarhülse Diam. trocar sleeve	Durchm. Instrument Diam. instrument
T.8025.08	Ø 8,0 mm	Ø 5,5 mm
T.8025.10	Ø 10,0 mm	Ø 5,5 mm
T.8025.11	Ø 11,0 mm	Ø 5,5 mm
T.8025.12	Ø 12,5 mm	Ø 5,5 mm
T.8025.13	Ø 12,5 mm	Ø 10,0 mm



Reduzieraufsatz, abnehmbar
Reducer, removable

	Durchm. Trokarhülse Diam. trocar sleeve	Durchm. Instrument Diam. instrument
T.8026.10	Ø 10,0 mm	Ø 5,5 mm
T.8026.12	Ø 11,0 mm	Ø 5,5 mm
T.8026.14	Ø 12,5 mm	Ø 5,5 mm
T.8026.15	Ø 12,5 mm	Ø 10,0 mm
T.8026.16	Ø 15,0 mm	Ø 5,5 mm
T.8026.17	Ø 15,0 mm	Ø 10,0 mm
T.8026.18	Ø 20,0 mm	Ø 5,5 mm
T.8026.19	Ø 20,0 mm	Ø 10,0 mm



Zubehör für Trokare Accessories for trocars

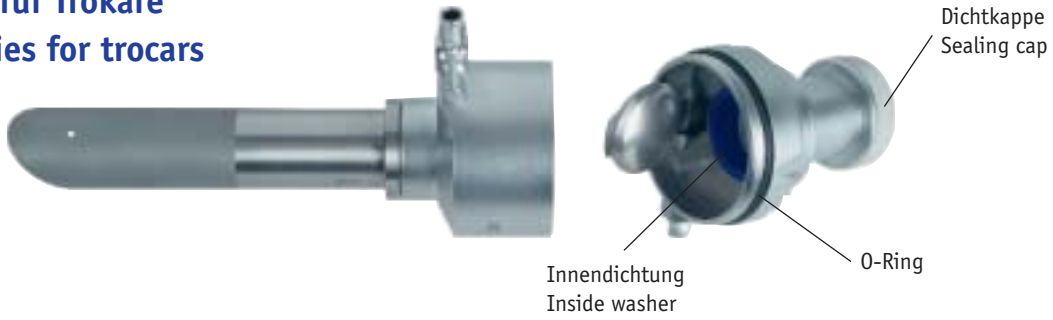

Dichtkappen Sealing caps



T.9050.08

T.9050.11

T.9050.13

T.9050.15

T.9110.10



T.9110.12



T.9050.25



T.9110.15



T.9050.26

Dichtkappen Konus Sealing caps for cone



T.9112.11



T.9112.12

Innendichtungen Inside washers



T.9050.14



T.9211.02



T.1315.01



T.1315.03

O-Ringe O-Rings



T.1315.00



T.2315.00



T.2815.00



T.2515.01

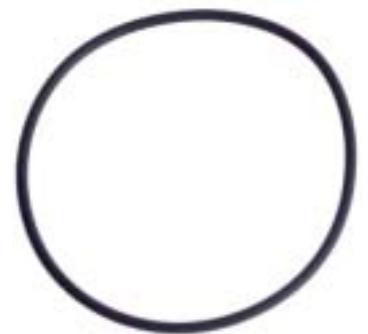

T.2515.02

Zubehör für Trokare Accessories for trocars



Dichtkappen für "light line" Trokarhülsen (Seite 9-11) und Trokarhülsen mit Trompetenventil (Seite 14)
Sealing caps for "light line" trocar sleeves (page 9-11) and trocar sleeves with trumpet valve (page 14)

Dichtkappen Sealing caps	Durchmesser Diameter	Farbe Colour	Perforation Perforation
T.9050.08	Ø 3,0 mm	rot/red	2 mm
T.9050.08	Ø 3,5 mm	rot/red	2 mm
T.9050.11	Ø 5,0 mm	rot/red	4 mm
T.9050.11	Ø 5,5 mm	rot/red	4 mm
T.9110.10	Ø 8,0 mm	rot/red	7 mm
T.9110.12	Ø 10,0 mm	blau/blue	8 mm
T.9110.12	Ø 11,0 mm	blau/blue	8 mm
T.9050.25	Ø 12,5 mm	grün/green	11 mm
T.9050.25	Ø 13,0 mm	grün/green	11 mm
T.9110.15	Ø 15,0 mm	grau/grey	13 mm
T.9050.26	Ø 20,0 mm	grau/grey	18 mm

Zubehör für Automatiktrokarhülsen (Seite 12)
Accessories for automatic trocar sleeves (page 12)

Trokarhülse Trocar sleeve	Durchmesser Diameter	Dichtkappen Sealing caps	Farbe Colour	Perforation Perforation	O-Ring O-ring	O-Ring Größe O-ring size	Innendichtung Inside washer	Farbe Colour
T.8012.24	Ø 3,5 mm	T.9050.08	rot/red	2 mm	T.1315.00	14 x 1,5 mm	T.9211.03	schwarz/black
T.8012.25	Ø 5,0 mm	T.9050.11	rot/red	4 mm	T.2315.00	23 x 1,5 mm	T.9050.14	grau/grey
T.8012.26	Ø 5,5 mm	T.9050.11	rot/red	4 mm	T.2315.00	23 x 1,5 mm	T.9050.14	grau/grey
T.8012.29	Ø 6,0 mm	T.9050.13	rot/red	5 mm	T.2315.00	23 x 1,5 mm	T.9050.14	grau/grey
T.8012.34	Ø 6,5 mm	T.9050.13	rot/red	5 mm	T.2315.00	23 x 1,5 mm	T.9050.14	grau/grey
T.8012.27	Ø 7,0 mm	T.9050.15	rot/red	6 mm	T.2315.00	23 x 1,5 mm	T.9050.14	grau/grey
T.8012.28	Ø 8,0 mm	T.9010.10	rot/red	7 mm	T.2315.00	23 x 1,5 mm	T.9050.14	grau/grey
T.8012.30	Ø 10,0 mm	T.9010.12	blau/blue	8 mm	T.2815.00	28 x 1,5 mm	T.9211.02	gelb/yellow
T.8012.31	Ø 11,0 mm	T.9010.12	blau/blue	8 mm	T.2815.00	28 x 1,5 mm	T.9211.02	gelb/yellow
T.8012.32	Ø 12,5 mm	T.9050.25	grün/green	11 mm	T.2815.00	28 x 1,5 mm	T.9211.02	gelb/yellow

Dichtkappen für HASSON Konus (Seite 15 und 16)
Sealing caps for HASSON cone (pages 15 and 16)

Dichtkappen Sealing caps	Farbe Colour	Perforation Perforation	Konus Cone	Durchmesser Diameter
T.9112.09	rot/red	4,1 mm	T.8014.83	Ø 3,5 mm
T.9112.11	grau/grey	6 mm	T.8014.85	Ø 5,0 mm
T.9112.11	grau/grey	6 mm	T.8014.86	Ø 5,5 mm
T.9050.25	grün/green	11 mm	T.8014.90	Ø 10,0 mm
T.9112.12	grau/grey	11,5 mm	T.8014.91	Ø 11,0 mm
T.9112.12	grau/grey	11,5 mm	T.8014.94	Ø 11,0 mm
T.9112.12	grau/grey	11,5 mm	T.8015.94	Ø 11,0 mm
T.9112.14	grau/grey	13 mm	T.8014.92	Ø 12,5 mm

Zubehör für Trokare Accessories for trocars



Zubehör für Mehrfachfunktion-Trokarhülsen (Seite 13)
Accessories for multiple function trocar sleeves (page 13)

Trokarhülse Trocar sleeve	Durchm. Diam.	Dichtkappen Sealing caps	Farbe Colour	Perforation Perforation	Innendichtung Inside washer	Farbe Colour
T.8017.03	Ø 3,5 mm	T.9050.08	rot/red	2 mm	T.9211.03	schwarz/black
T.8017.05	Ø 5 mm	T.9050.11	rot/red	4 mm	T.9050.14	grau/grey
T.8017.15	Ø 5,5 mm	T.9050.11	rot/red	4 mm	T.9050.14	grau/grey
T.8017.16	Ø 6 mm	T.9050.13	rot/red	5 mm	T.9050.14	grau/grey
T.8017.17	Ø 6,5 mm	T.9050.13	rot/red	5 mm	T.9050.14	grau/grey
T.8017.07	Ø 7 mm	T.9050.15	rot/red	6 mm	T.9050.14	grau/grey
T.8017.08	Ø 8 mm	T.9110.10	rot/red	7 mm	T.9050.14	grau/grey
T.8017.10	Ø 10 mm	T.9110.12	blau/blue	8 mm	T.9211.02	gelb/yellow
T.8017.11	Ø 11 mm	T.9110.12	blau/blue	8 mm	T.9211.02	gelb/yellow
T.8017.12	Ø 12,5 mm	T.9050.25	grün/green	11 mm	T.9211.02	gelb/yellow
T.8017.18	Ø 13 mm	T.9050.25	grün/green	11 mm	T.9211.02	gelb/yellow

Trokarhülse Trocar sleeve	Durchm. Diam.	Dichtkappen Sealing caps	Farbe Colour	Perforation Perforation	Innendichtung Inside washer	Farbe Colour	O-Ring O-ring	O-Ring Größe O-ring size
T.8017.19	Ø 15 mm	T.9110.15	grau/grey	13 mm	T.1315.01	grün/green	T.2515.01	35 x 1,5 mm
T.8017.20	Ø 20 mm	T.9050.26	grau/grey	18 mm	T.1315.03	blau/blue	T.2515.02	41 x 1,5 mm

Dichtkappen für Reduzieraufsätze (Seite 23)
Sealing caps for reducer (page 23)

Reduzierer Reducer	Durchmesser Diameter	Dichtkappen Sealing caps	Farbe Colour	Perforation Perforation
T.8024.09	Ø 5,5 - 3 mm	T.9050.08	rot/red	2 mm
T.8024.08	Ø 8 - 5,5 mm	T.9050.11	rot/red	4 mm
T.8024.10	Ø 10 - 5,5 mm	T.9050.11	rot/red	4 mm
T.8024.20	Ø 11 - 5,5 mm	T.9050.11	rot/red	4 mm
T.8024.21	Ø 12,5 - 5,5 mm	T.9050.11	rot/red	4 mm
T.8024.22	Ø 12,5 - 10 mm	T.9110.12	blau/blue	8 mm
T.8024.23	Ø 13 - 5,5 mm	T.9050.11	rot/red	4 mm

Dichtkappen für Reduzierhülsen (Seite 22)
Sealing caps for reducer sleeves (page 22)

Reduzierer Reducer sleeve	Durchmesser Diameter	Dichtkappen Sealing caps	Farbe Colour	Perforation Perforation
T.1106.05	Ø 5,5 - 3 mm	T.9050.11	rot/red	4 mm
T.1106.06	Ø 10 - 5,5 mm	T.9050.11	rot/red	4 mm
T.1106.10	Ø 11 - 5,5 mm	T.9050.11	rot/red	4 mm
T.1106.12	Ø 12,5 - 5,5 mm	T.9050.11	rot/red	4 mm
T.1106.13	Ø 12,5 - 10 mm	T.9110.12	blau/blue	8 mm
T.1106.15	Ø 15 - 10 mm	T.9110.12	blau/blue	8 mm
T.1106.16	Ø 15 - 11 mm	T.9110.12	blau/blue	8 mm
T.1106.20	Ø 20 - 10 mm	T.9110.12	blau/blue	8 mm
T.1106.21	Ø 20 - 11 mm	T.9110.12	blau/blue	8 mm
T.1106.22	Ø 20 - 15 mm	T.9110.15	grau/grey	13 mm

Zubehör Accessories



Dilatations-Set, bestehend aus Dilatatorhülse und Dilatationsdorn
Dilation Set, consisting of dilator sleeve and dilator

T.0511.01	Ø 5,0 mm → 10,0 mm
T.0511.00	Ø 5,0 mm → 11,0 mm
T.0511.03	Ø 10,0 mm → 15,0 mm
T.0511.05	Ø 11,0 mm → 15,0 mm
T.0511.06	Ø 5,0 mm → 15,0 mm
T.0511.08	Ø 5,0 mm → 20,0 mm
T.0511.10	Ø 10,0 mm → 20,0 mm
T.0511.12	Ø 11,0 mm → 20,0 mm



Spreizer für die Gallenblasenextraktion, 3 Valven
Retractor for gall bladder extraction, 3 blades

S.0603.00



Insufflationsnadeln Insufflation needles



VERESS Insufflationsnadel, **Hochfluß**
VERESS insufflation needle, **High flow**

T.0102.10	L = 10 cm
T.0102.12	L = 12 cm
T.0102.15	L = 15 cm
T.0102.18	L = 18 cm

empfohlen für alle GIMMI® Insufflatoren
recommended for all GIMMI® insufflators

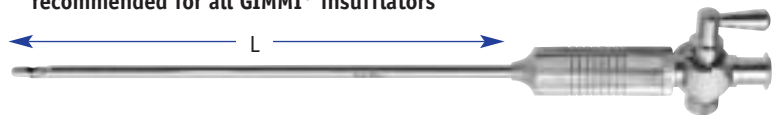

VERESS Insufflationsnadel Ø 2,0 mm
VERESS insufflation needle Ø 2,0 mm

T.0100.05	L = 5,5 cm
T.0100.07	L = 7 cm
T.0100.08	L = 8 cm
T.0100.10	L = 10 cm
T.0100.12	L = 12 cm
T.0100.14	L = 14 cm
T.0100.15	L = 15 cm
T.0100.18	L = 18 cm
T.0100.21	L = 20 cm



VERESS Kanüle, mit austauschbarer Außenkanüle
VERESS cannula, with removable outer cannula

Kanüle komplett Cannula complete	Außenkanüle allein, 6 Stk./Pckg. Outer cannula only, 6 pcs./Box	Länge Length
T.0103.10	T.0103.20	10 cm
T.0103.12	T.0103.22	12 cm
T.0103.15	T.0103.25	15 cm



GS - Kanüle mit Doppel-LUER LOCK, Ø 2,0 mm
GS - cannula with double LUER LOCK, Ø 2,0 mm

T.0104.10	L = 10 cm
T.0104.12	L = 12 cm
T.0104.15	L = 15 cm
T.0104.18	L = 18 cm



Saug- und Spülkanülen Suction and irrigation cannulas



Griff allein
Handle only

T.0510.01

Silikonschlauch 10 x 3 mm, wiederverwendbar
Silicone tubing 10 x 3 mm, reusable

T.0510.99 | 3 mtr.



Rohr, auswechselbar, Ø 10 mm
Tube, interchangeable, Ø 10 mm

T.0510.02 | 33 cm

T.0510.11 | 45 cm



Rohr, auswechselbar, Ø 5 mm
Tube, interchangeable, Ø 5 mm

T.0510.03 | 33 cm

T.0510.05 | 45 cm



CULLIS Rohr auswechselbar Ø 5 mm, zur gemeinsamen Verwendung mit 10 mm Rohr (T.0510.02)
CULLIS tube interchangeable Ø 5 mm, for use together with 10 mm tube (T.0510.02)

T.0510.04 | 33 cm

Saug- / Spüler - Satz bestehend aus: Griff (T.0510.01) und auswechselbaren Rohren Ø 5 mm (T.0510.03) und Ø 10 mm (T.0510.02)
Suction / irrigation set consisting of: Handle (T.0510.01) and interchangeable tubes Ø 5 mm (T.0510.03) and Ø 10 mm (T.0510.02)

T.0510.00

CULLIS Saug- / Spüler - Satz bestehend aus: Griff (T.0510.01) und auswechselbaren Rohren Ø 5 mm (T.0510.04) und Ø 10 mm (T.0510.02)
CULLIS Suction / irrigation set consisting of: Handle (T.0510.01) and interchangeable tubes Ø 5 mm (T.0510.04) and Ø 10 mm (T.0510.02)

T.0510.10

Saug- / Spülkanüle
mit Kanal für Laser Fiber

Suction / irrigation tube
with channel for laser fibre

T.0035.05



Saug- / Spülkanüle
mit zwei Trompetenventilen,
graduirt mit Kanal für Laser Fiber

Suction / irrigation tube with
two trumpet valves, graduated
with channel for laser fibre



T.0037.04



Saug- und Spülkanülen Suction and irrigation cannulas



Handgriffe
Handles

T.0032.05	Griff mit Schlauchansatz und zwei Trompetenventilen Handle with host join and two trumpet valves	
T.0032.14	Griff mit LUER LOCK und zwei Trompetenventilen Handle with LUER LOCK and two trumpet valves	
T.0032.15	Griff mit Schiebeventil Handle with sliding valve	

Saug und Spülrohre
Suction / irrigation tubes

T.0032.07	33 cm	Rundlochsauger (Standard) Suction tube with holes (Standard)	
T.0032.08	33 cm	Sauger, stumpf Suction tube, blunt	
T.0032.09	33 cm	Sauger, stumpf Suction tube, blunt	
T.0032.10	33 cm	Rundlochsauger Suction tube with holes	
T.0032.11	50 cm	Sauger, stumpf Suction tube, blunt	
T.0032.12	33 cm	Punktionsnadelsauger Aspiration needle suction tube	
T.0032.13	33 cm	Aqua Dissektor Kanüle Aqua dissector cannula	

SATZ Saug- / Spülrohre bestehend aus: 7 auswechselbaren Rohren und 1 Handgriff
SET of suction / irrigation tubes, consisting of: 7 changeable tubes and 1 handle

T.0032.06	Satz mit Handgriff T.0032.05 / Set with handle T.0032.05
T.0032.16	Satz mit Handgriff T.0032.14 / Set with handle T.0032.14
T.0032.17	Satz mit Handgriff T.0032.15 / Set with handle T.0032.15

Saug- und Spülkanülen Suction and irrigation cannulas



Zweiwegehahn, LUER LOCK Ansätze für **T.0040.05**, **T.0041.05**, **T.0043.05** und **T.0043.06**
Two way stopcock, LUER LOCK connection for **T.0040.05**, **T.0041.05**, **T.0043.05** and **T.0043.06**



T.0038.05

Führungstubus, gebogen,
mit LUER LOCK Ansatz

Guide tube, curved,
with LUER LOCK connection



T.0040.05	Ø 5 mm	33 cm
------------------	--------	-------

Punktions- und Injektionskanüle,
mit LUER LOCK Ansatz

Aspiration and injection cannula,
with LUER LOCK connection



T.0043.05	Ø 5 mm	33 cm
------------------	--------	-------

T.0043.06	Ø 5 mm	45 cm
------------------	--------	-------

Nadel-Sonde
Needle probe



T.0039.05	Ø 5 mm	33 cm
------------------	--------	-------

Taststab, graduiert
Palpation probe, graduated



T.0042.05	Ø 5 mm	33 cm
------------------	--------	-------

Modulares Saug- und Spülsystem mit auswechselbaren Rohren Modular suction and irrigation system with interchangeable tubes



Saug- und Spülhandgriff mit 2 Trompetenventilen, abnehmbarer Griffplatte für adaptierbare Rohre (M8 x 1 mm), Schlauchanschluß, sowie seitlichem LL-Anschluß (weiblich)

Suction / irrigation handle with 2 trumpet valves and detachable handle plate for adaptable tubes (M8 x 1 mm), universal hose connector and lateral female LL-connector



T.0044.01

Saug- und Spül - Pistolenhandgriff mit wartungsfreiem Zweiwegeventil, für adaptierbare Rohre (M8 x 1 mm), 2 Universal - Schlauchanschlüsse



Suction / irrigation pistol handle with maintenance-free two-way valve, for adaptable tubes (M8 x 1 mm), 2 universal tube connectors



T.0044.02

Adaptierbares Saug- / Spülrohr (Anschluß M8 x 1 mm) mit 4 oder 4x4 seitlichen Bohrungen (Bienenkorb) am distalen Ende

Adaptable suction / irrigation tube (connection M8 x 1 mm) with 4 or 4x4 lateral holes at the distal end

mit 4 Bohrungen with 4 holes	mit 4x4 Bohrungen with 4x4 holes	Durchm. Diam.	
T.0044.03	T.0044.13	Ø 3 mm	
T.0044.05	T.0044.15	Ø 5 mm	
T.0044.10	T.0044.20	Ø 10 mm	

Adaptierbares Optik-Spülrohr mit abgewinkelter Spülöffnung (Anschluß M8 x 1 mm)

Adaptable endoscope flushing tube with angled flush opening (connector M8 x 1 mm)

T.0044.30

Ø 3 mm



Adaptierbares Saug- / Spülrohr mit Punktions- / Injektionsnadel Ø 1 mm (Anschluß M8x1 mm)

Adaptable suction / irrigation tube with aspiration / injection needle Ø 1 mm (connection M8x1 mm)

T.0044.31

Ø 5 mm



Modulares Multifunktions-Saug-/Spülsystem mit Instrumentenkanal Modular multifunctional suction and irrigation system with instrument Channel

Dieses modulare Multifunktions-Saug-/Spülsystem setzt sich zusammen aus einem Pistolenhandgriff mit wartungsfreiem Zweiwegeventil und dem verschließbaren Instrumentenkanal Ø 5 mm. Der Instrumentenkanal öffnet sich beim Einführen und verschließt sich beim Entnehmen von Instrumenten automatisch. Alternativ kann der Instrumentenkanal manuell durch Tastenbetätigung geöffnet / geschlossen werden, z. B. um das Entnehmen von Hakeninstrumenten oder Biopsien zu erleichtern. Das System kann zur Reinigung einfach zerlegt und zusammengesetzt werden.

The modular multifunctional suction and irrigation system consists of a pistol handle with a maintenance-free two-way valve and a lockable instrument channel Ø 5 mm for irrigation and aspiration during laparoscopy. The instrument channel automatically opens when instruments are inserted and closes when they are removed. Alternatively the instrument channel can be opened manually by pressing a pushbutton, e. g. to remove a hook-type instrument or a biopsy. The system can easily be dis/assembled for cleaning.

(die Rohre T.0044.03 - T.0044.31 mit Anschluß M8 x 1 mm können adaptiert werden)
(the tubes T.0044.03 - T.0044.31 with a M8 x 1 mm connection can be adapted)

Saug-/Spül - Pistolenhandgriff, mit wartungsfreiem Zweiwege-Ventil, Instrumentenkanal Ø 5 mm, mit automatisch und manuell bedienbarem Verschuß und 2 Universal-Schlauchanschlüssen

Suction / irrigation pistol handle, with maintenance-free two-way valve, Instrument channel Ø 5 mm, with automatic and manual closure and 2 universal tube connectors.

T.0045.00

Adaptierbares Saug-/Spülrohr, **Metall**, Außen-Ø 10 mm, Anschluß M8 x 1 mm, für Instrumente Ø 5 mm, Innen-Ø am distalen Ende: Ø 6 mm

Adaptable suction / irrigation tube, **metal**, outer-Ø 10 mm connection M8 x 1 mm, for use with instruments Ø 5 mm Inner-Ø at distal end: Ø 6 mm

T.0045.01

230 mm

Adaptierbares Saug-/Spülrohr, **Kunststoff**, Außen-Ø 10 mm, Anschluß M8 x 1 mm, für Instrumente Ø 5 mm, Innen-Ø am distalen Ende: Ø 6 mm

Adaptable suction / irrigation tube, **plastic**, outer-Ø 10 mm connection M8x1 mm, for use with instruments Ø 5 mm Inner-Ø at distal end: Ø 6 mm

T.0045.02

230 mm

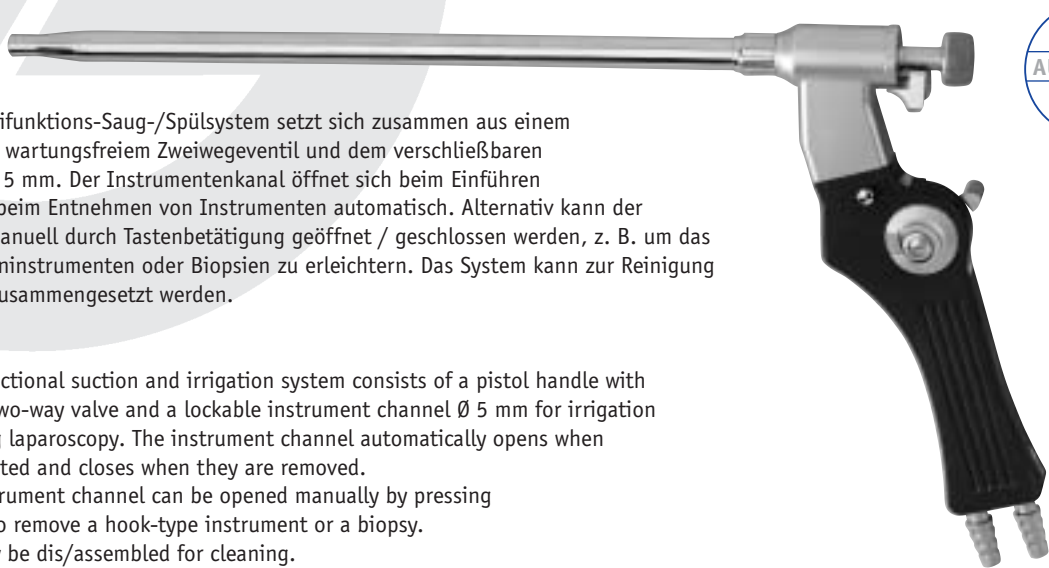

GIMMI® - ALPHAQUICK System - die neue Generation laparoskopischer Instrumente

GIMMI® - ALPHAQUICK System - the new generation of laparoscopic instruments

Handgriff mit integriertem Schaft
Handle with fixed shaft

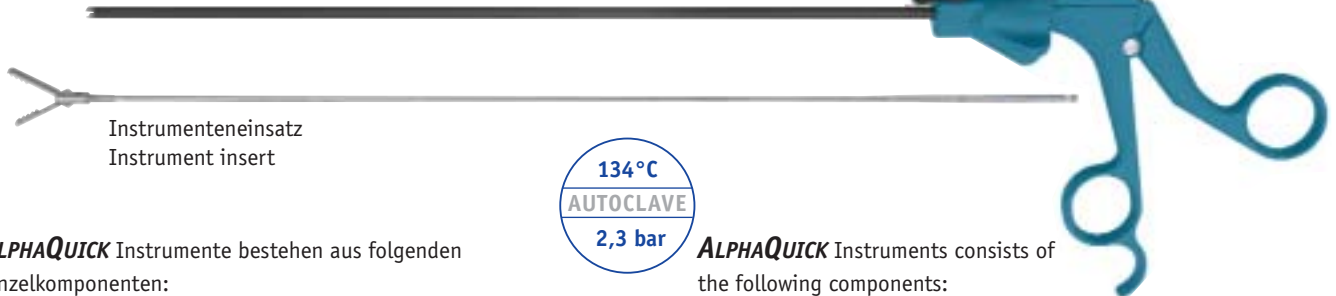

Instrumenteneinsatz
Instrument insert

ALPHAQUICK Instrumente bestehen aus folgenden Einzelkomponenten:

- PEEK-Handgriff mit integriertem Schaft
- Instrumenten-Einsatz

ALPHAQUICK Instruments consists of the following components:

- PEEK-handle with fixed shaft
- Instrument insert

Die besonderen Vorteile des **ALPHAQUICK System** sind:

Zerlegbarkeit:

- Durch die Zerlegbarkeit in nur 2 Teile ist eine schnelle Demontage und ein schneller Zusammenbau sichergestellt
- Modularer Aufbau, dadurch freie Kombinierbarkeit von Arbeitseinsätzen und Griffen
- Keine aufwendigen Instrumentenansammlungen
- Optimale Reinigung und Sterilisation

Benutzerfreundlichkeit:

- GIMMI® – Easy Rotation
- 360° drehbar bedeutet höhere Flexibilität
- Rotation wird beim Schließen des PEEK-Griffes arretiert
- Abgewinkelter HF-Anschluß
- Ergonomische, einfache und sichere Einhandbedienung
- Erhältlich in den Größen Ø 5,0 mm, und Ø 10,0 mm
- Verfügbar in Längen 25 cm, 33 cm und 45 cm
- Weniger Gewicht – dadurch komfortabler

Wirtschaftlichkeit:

- PEEK-Multifunktionsgriff oder PEEK-Griff ohne Sperre
- Vollständig autoklavierbar
- Kostengünstig durch Ersatzbeschaffung von Einzelteilen
- Bei eventuell notwendigen Reparaturen wird nur das defekte Teil ausgetauscht
- Durch Variationsmöglichkeiten – weniger Instrumente erforderlich

Special features of the **ALPHAQUICK System**:

Detachability:

- Instrument consists of only 2 components – therefore quick and easy (dis)assembly
- Modular composition facilitates free interchange of inserts and handles
- No costly accumulation of instruments
- Optimal cleaning and sterilisation

Handling:

- GIMMI® Easy Rotation
- 360° rotation ensures high versatility
- Rotation is stopped when handle is closed
- Oblique HF connection
- Ergonomic, easy and precise single-hand use
- Available in Ø 5,0 mm, and Ø 10,0 mm
- Available in 25 cm, 33 cm, and 45 cm length
- Light weight, therefore great comfort

Cost effective:

- PEEK multifunction handle or PEEK handle without ratchet
- Fully autoclavable
- Components separately available
- Only damaged component needs to be replaced
- Versatility, means fewer instruments required

*PEEK ist die chemische Kurzbezeichnung für ein Carbonfaserverstärktes röntgendurchlässiges Polymer mit hoher Biegefestigkeit und Temperaturverträglichkeit > 250C°.

*PEEK is the short chemical denomination of carbon fiber reinforced, radiolucent polymer with high stiffness and temperature tolerance > 250C°.

GIMMI® - ALPHAQUICK System - die neue Generation laparoskopischer Instrumente
GIMMI® - ALPHAQUICK System - the new generation of laparoscopic instruments

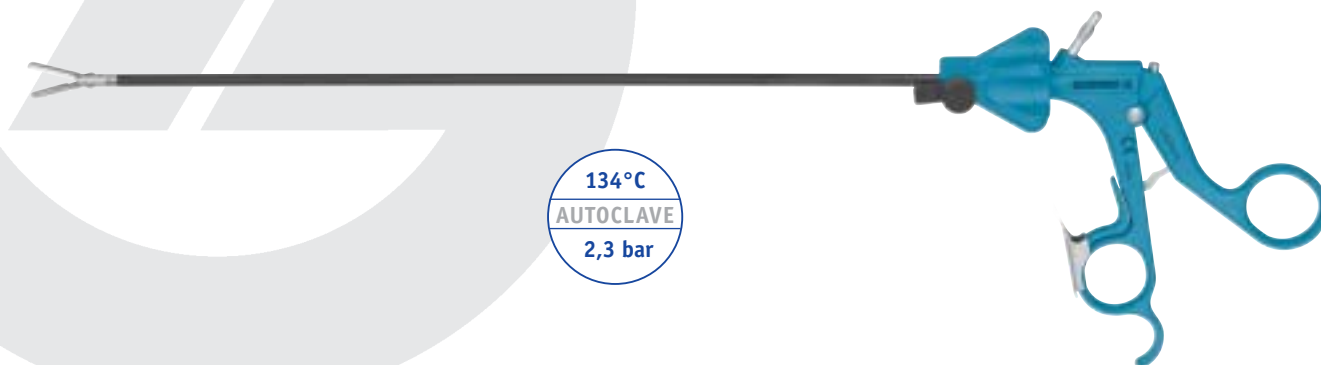

GIMMI® **ALPHAQUICK System** mit neuester Sperrentechnologie bietet dem Anwender ein universelles Instrument zur Verwendung einer Vielzahl von Einsätzen. Die integrierte Sperre kann sehr einfach aktiviert oder deaktiviert werden. Ebenso einfach kann die Sperre durch Drücken der Taste gelöst werden. Dieses Sperren-System ermöglicht es, eine Vielzahl von verschiedenen Einsätzen, von der Faßzange bis zum Nadelhalter, mit nur einem **ALPHAQUICK Multifunktionsgriff** zu verwenden.

GIMMI® **ALPHAQUICK System** Handle with new ratchet technology, offers the user a universal instrument that can be used for many different applications. The integrated ratchet can easily be activated or deactivated. The ratchet can be released by just pressing the trigger. This ratchet system makes it possible to use all different inserts (graspers, forceps etc.) with only one **ALPHAQUICK System** multifunction handle.

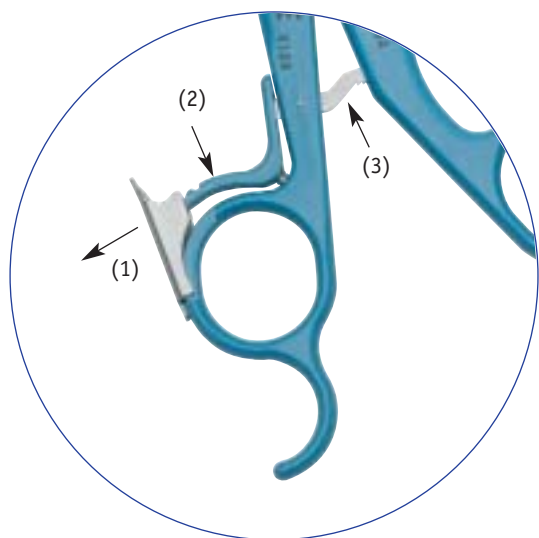

Zur Aktivierung der Sperre (3) drücken Sie den Sperrendrucker (2) nach unten, damit geht automatisch der Hebel (1) nach vorn.
 Um die Sperre zu lösen, drücken Sie den Sperrendrucker (2) nach unten.

To activate the lock (3) press down the lock actuator (2) and the lever (1) will automatically move outward.
 To release the lock press down the lock actuator (2).

Zur dauerhaften Deaktivierung der Sperre (3) drücken Sie einfach den Hebel (1) in Pfeilrichtung bis der Hebel einrastet.

HINWEIS:
Nur mit aktivierter Sperre sterilisieren

To deactivate the lock (3) permanently, simply press the lever (1) in the direction indicated by the arrow, until it engages.

NOTE:
Always activate the lock for sterilisation

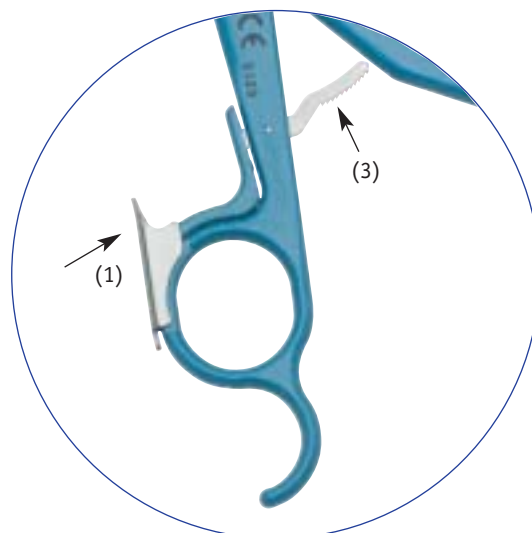

GIMMI® - ALPHAQUICK System - die neue Generation laparoskopischer Instrumente GIMMI® - ALPHAQUICK System - the new generation of laparoscopic instruments

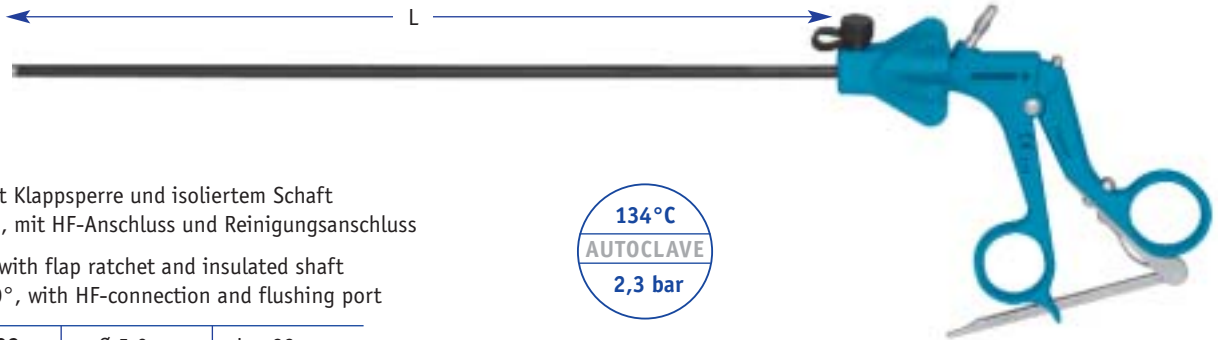

PEEK-Griff mit Klappsperre und isoliertem Schaft
drehbar 360°, mit HF-Anschluss und Reinigungsanschluss

PEEK-handle with flap ratchet and insulated shaft
rotatable 360°, with HF-connection and flushing port

Z.0005.00	Ø 5,0 mm	L = 33 cm
------------------	----------	-----------

Vorteile:

- Durch die Verwendung von PEEK perfekte elektrische Isolation (keine blanken Teile)
- Weniger Gewicht, dadurch komfortabler
- Hervorragende Ergonomie
- Demontage und Zusammenbau einfach und schnell
- Wegklappbare Sperre, dadurch höchster Komfort

Advantages:

- Use of PEEK material – therefore perfect electrical insulation (no unprotected parts)
- Lightweight – high comfort
- Excellent ergonomics
- Easy and fast dismantling and assembly
- Selectable ratchet for more comfort

Wichtig!!

Es sind alle Einsätze, die auf den Seiten 39 bis 51 abgebildet sind, verwendbar.

Important!!

Fits all inserts, illustrated on page 39 to 51.



Sperre ist in
2 Positionen weg-
klappbar

Ratchet is
selectable in
2 positions



Faßzangen und Dissektionszangen, Ø 5 mm, 25 cm, dreh- und zerlegbar, mit Reinigungsanschluss

Grasping and dissecting forceps, Ø 5 mm, 25 cm, rotatable and detachable, with flushing port



Z.0005.23

PEEK-Griff mit isoliertem Schaft,
ohne Sperre, drehbar 360°,
mit HF-Anschluss und Reinigungsanschluss

PEEK-handle with insulated shaft,
without ratchet, rotatable 360°,
with HF-connection and flushing port

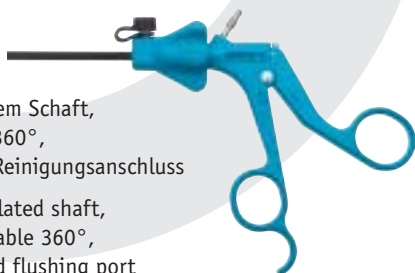







Z.0005.24

PEEK-Multifunktionsgriff mit
isoliertem Schaft, drehbar 360°,
mit HF-Anschluss und Reinigungsanschluss

PEEK-Multifunction handle
insulated shaft, rotatable 360°,
with HF-connection and flushing port



Einsatz allein Insert only	Instrument komplett / Instrument complete			
	Griff ohne Sperre Handle without ratchet	Multifunktionsgriff Multifunction handle		
Z.1025.60	Z.1025.23	Z.1025.24	COBRA Faßzange COBRA grasping forceps	 2/3
Z.1525.60	Z.1525.23	Z.1525.24	MARYLAND Dissektor, leicht gebogen, doppelbeweglich MARYLAND dissecting forceps, curved slightly, double action	 2/3
Z.1625.60	Z.1625.23	Z.1625.24	DORSEY Darmklemme, Maullänge 40 mm, doppelbeweglich DORSEY intestinal forceps, jaw length 40 mm, double action	 2/3
Z.2025.60	Z.2025.23	Z.2025.24	DEBAKEY Faßzange, Maullänge 20 mm, doppelbeweglich DEBAKEY grasping forceps, jaw length 20 mm, double action	 2/3
Z.2225.60	Z.2225.23	Z.2225.24	Präparier- und Faßzange, stumpf Dissecting and grasping forceps, blunt	 2/3
Z.2925.60	Z.2925.23	Z.2925.24	Darmgreifer, doppelbeweglich Bowel forceps, double action	 2/3
Z.4025.60	Z.4025.23	Z.4025.24	HEAVY DUTY (FUNDUS) Faßzange, doppelbeweglich HEAVY DUTY (FUNDUS) grasping forceps, double action	 2/3

Faßzangen, Dissektionszangen und Scheren, Ø 5 mm, 25 cm, dreh- und zerlegbar, mit Reinigungsanschluss

Grasping forceps, dissecting forceps and scissors, Ø 5 mm, 25 cm, rotatable and detachable, with flushing port



Z.0005.23

PEEK-Griff mit isoliertem Schaft, **ohne Sperre**, drehbar 360°, mit HF-Anschluss und Reinigungsanschluss

PEEK-handle with insulated shaft, **without ratchet**, rotatable 360°, with HF-connection and flushing port

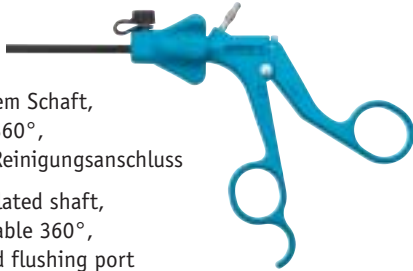



Z.0005.24

PEEK-Multifunktionsgriff mit isoliertem Schaft, drehbar 360°, mit HF-Anschluss und Reinigungsanschluss

PEEK-Multifunction handle insulated shaft, rotatable 360°, with HF-connection and flushing port



Einsatz allein Insert only	Instrument komplett / Instrument complete			
	Griff ohne Sperre Handle without ratchet	Multifunktionsgriff Multifunction handle		
Z.4525.60	Z.4525.23	Z.4525.24	BABCOCK Faßzange, Maullänge 30 mm, doppelbeweglich BABCOCK grasping forceps, jaw length 30 mm, double action	 2/3
Z.5425.60	Z.5425.23	-	Hakenschere Hook scissors	 2/3
Z.5525.60	Z.5525.23	-	METZENBAUM ENDO-Schere, stark gebogen, doppelbeweglich METZENBAUM ENDO-scissors, curved strongly, double action	 2/3

**Faßzangen und Dissektionszangen, Ø 5 mm, 33 cm,
dreh- und zerlegbar, mit Reinigungsanschluss**

**Grasping and dissecting forceps, Ø 5 mm, 33 cm,
rotatable and detachable, with flushing port**



Z.0005.01

PEEK-Griff mit isoliertem Schaft,
ohne Sperre, drehbar 360°,
mit HF-Anschluss und Reinigungsanschluss

PEEK-handle with insulated shaft,
without ratchet, rotatable 360°,
with HF-connection and flushing port

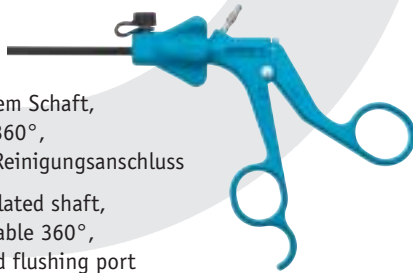

Z.0005.02

PEEK-Multifunktionsgriff mit
isoliertem Schaft, drehbar 360°,
mit HF-Anschluss und Reinigungsanschluss

PEEK-Multifunction handle
insulated shaft, rotatable 360°,
with HF-connection and flushing port



Einsatz allein Insert only	Instrument komplett / Instrument complete			
	Griff ohne Sperre Handle without ratchet	Multifunktionsgriff Multifunction handle		
Z.1035.60	Z.1035.01	Z.1035.02	COBRA Faßzange COBRA grasping forceps	 2/3
Z.2535.60	Z.2535.01	Z.2535.02	COBRA Faßzange, doppelbeweglich COBRA grasping forceps, double action	 2/3
Z.1135.60	Z.1135.01	Z.1135.02	ALLIS Faßzange ALLIS grasping forceps	 2/3
Z.1136.60	Z.1136.01	Z.1136.02	ALLIS Faßzange, gefenestert ALLIS grasping forceps, fenestrated	 2/3
Z.1137.60	Z.1137.01	Z.1137.02	ALLIS Faßzange, schmal ALLIS grasping forceps, narrow	 2/3
Z.1140.60	Z.1140.01	Z.1140.02	ALLIS Faßzange, gefenestert, langes Maul ALLIS grasping forceps, fenestrated, long jaw	 2/3
Z.1139.60	Z.1139.01	Z.1139.02	Faßzange mit Zähnen, doppelbeweglich Grasping forceps with teeth, double action	 2/3

Faßzangen und Dissektionszangen, Ø 5 mm, 33 cm, dreh- und zerlegbar, mit Reinigungsanschluss

Grasping and dissecting forceps, Ø 5 mm, 33 cm, rotatable and detachable, with flushing port



Z.0005.01

PEEK-Griff mit isoliertem Schaft, **ohne Sperre**, drehbar 360°, mit HF-Anschluss und Reinigungsanschluss

PEEK-handle with insulated shaft, **without ratchet**, rotatable 360°, with HF-connection and flushing port

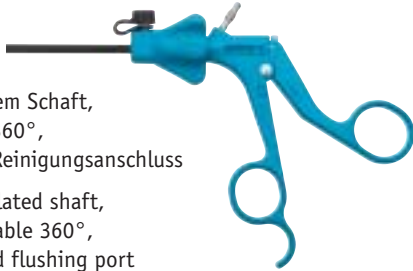







Z.0005.02

PEEK-Multifunktionsgriff mit isoliertem Schaft, drehbar 360°, mit HF-Anschluss und Reinigungsanschluss

PEEK-Multifunction handle insulated shaft, rotatable 360°, with HF-connection and flushing port



Einsatz allein Insert only	Instrument komplett / Instrument complete			
	Griff ohne Sperre Handle without ratchet	Multifunktionsgriff Multifunction handle		
Z.1138.60	Z.1138.01	Z.1138.02	Faßzange, 3:3 Zähne, doppelbeweglich Grasping forceps, 3:3 teeth, double action	 2/3
Z.1235.60	Z.1235.01	Z.1235.02	Faßzange, 1:2 Zähne Grasping forceps, 1:2 teeth	 2/3
Z.2035.60	Z.2035.01	Z.2035.02	DEBAKEY Faßzange, Maullänge 20 mm, doppelbeweglich DEBAKEY grasping forceps, jaw length 20 mm, double action	 2/3
Z.2135.60	Z.2135.01	Z.2135.02	Faßzange, stumpf Grasping forceps, blunt	 2/3
Z.2235.60	Z.2235.01	Z.2235.02	Präparier- und Faßzange, stumpf Dissecting and grasping forceps, blunt	 2/3
Z.2236.60	Z.2236.01	Z.2236.02	Präparier- und Faßzange, mit Dorn, stumpf Dissecting and grasping forceps, with needle, blunt	 2/3
Z.2335.60	Z.2335.01	Z.2335.02	DELPHIN Präparier- und Faßzange, doppelbeweglich DOLPHIN dissecting and grasping forceps, double action	 2/3

**Faßzangen und Dissektionszangen, Ø 5 mm, 33 cm,
dreh- und zerlegbar, mit Reinigungsanschluss**

**Grasping and dissecting forceps, Ø 5 mm, 33 cm,
rotatable and detachable, with flushing port**



Z.0005.01

PEEK-Griff mit isoliertem Schaft,
ohne Sperre, drehbar 360°,
mit HF-Anschluss und Reinigungsanschluss

PEEK-handle with insulated shaft,
without ratchet, rotatable 360°,
with HF-connection and flushing port

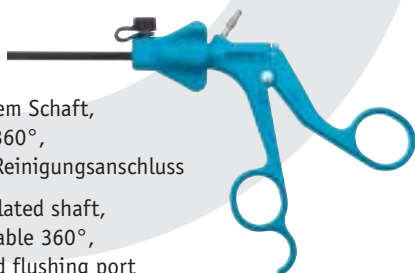







Z.0005.02

PEEK-Multifunktionsgriff mit
isoliertem Schaft, drehbar 360°,
mit HF-Anschluss und Reinigungsanschluss

PEEK-Multifunction handle
insulated shaft, rotatable 360°,
with HF-connection and flushing port



Einsatz allein Insert only	Instrument komplett / Instrument complete			
	Griff ohne Sperre Handle without ratchet	Multifunktionsgriff Multifunction handle		
Z.2735.60	Z.2735.01	Z.2735.02	DELPHIN Präparier- und Faßzange mit Löffel, doppelbeweglich DOLPHIN dissecting and grasping forceps, with spoon, double action	 2/3
Z.2435.60	Z.2435.01	Z.2435.02	Präparier- und Faßzange, mit Löffel, spitz, doppelbeweglich Dissecting and grasping forceps, with spoon, tapered end, double action	 2/3
Z.2635.60	Z.2635.01	Z.2635.02	Faßzange, gefenstert, doppelbeweglich Grasping forceps, fenestrated, double action	 2/3
Z.2835.60	Z.2835.01	Z.2835.02	DUCK BILL Präparier- und Faßzange DUCK BILL dissecting and grasping forceps	 2/3
Z.2836.60	Z.2836.01	Z.2836.02	CLEEVE DUCK BILL Präparier- und Faßzange, doppelbeweglich CLEEVE DUCK BILL dissecting and grasping forceps, double action	 2/3
Z.2937.60	Z.2937.01	Z.2937.02	Faßzange doppelbeweglich, flach Grasping forceps double action, flat	 2/3
Z.1435.60	Z.1435.01	Z.1435.02	NEEDLE NOSE Faßzange NEEDLE NOSE grasping forceps	 2/3

Faßzangen und Dissektionszangen, Ø 5 mm, 33 cm, dreh- und zerlegbar, mit Reinigungsanschluss

Grasping and dissecting forceps, Ø 5 mm, 33 cm, rotatable and detachable, with flushing port



Z.0005.01

PEEK-Griff mit isoliertem Schaft, ohne Sperre, drehbar 360°, mit HF-Anschluss und Reinigungsanschluss

PEEK-handle with insulated shaft, without ratchet, rotatable 360°, with HF-connection and flushing port

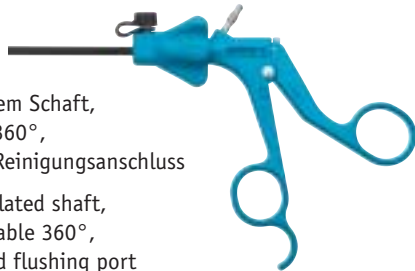







Z.0005.02

PEEK-Multifunktionsgriff mit isoliertem Schaft, drehbar 360°, mit HF-Anschluss und Reinigungsanschluss

PEEK-Multifunction handle insulated shaft, rotatable 360°, with HF-connection and flushing port



Einsatz allein Insert only	Instrument komplett / Instrument complete			
	Griff ohne Sperre Handle without ratchet	Multifunktionsgriff Multifunction handle		
Z.1436.60	Z.1436.01	Z.1436.02	NEEDLE NOSE Faßzange, doppelbeweglich NEEDLE NOSE grasping forceps, double action	 2/3
Z.1535.60	Z.1535.01	Z.1535.02	MARYLAND Dissektor, leicht gebogen, doppelbeweglich MARYLAND dissecting forceps, curved slightly, double action	 2/3
Z.2936.60	Z.2936.01	Z.2936.02	KELLY Faßzange, doppelbeweglich KELLY grasping forceps, double action	 2/3
Z.2637.60	Z.2637.01	Z.2637.02	Faßzange, gefenstert, doppelbeweglich, delikates Modell Grasping forceps, fenestrated, double action, delicate model	 2/3
Z.2939.60	Z.2939.01	Z.2939.02	Faßzange, schmal, doppelbeweglich Grasping forceps, narrow, double action	 2/3
Z.2938.60	Z.2938.01	Z.2938.02	Faßzange, gefenstert, kräftig, doppelbeweglich Grasping forceps, fenestrated, strong, double action	 2/3
Z.1538.60	Z.1538.01	Z.1538.02	MIXTER Dissektionszange, 90° abgewinkelt, doppelbeweglich MIXTER dissecting forceps, 90° angled, double action	 2/3

**Faßzangen und Dissektionszangen, Ø 5 mm, 33 cm,
dreh- und zerlegbar, mit Reinigungsanschluss**

**Grasping and dissecting forceps, Ø 5 mm, 33 cm,
rotatable and detachable, with flushing port**



Z.0005.01

PEEK-Griff mit isoliertem Schaft,
ohne Sperre, drehbar 360°,
mit HF-Anschluss und Reinigungsanschluss

PEEK-handle with insulated shaft,
without ratchet, rotatable 360°,
with HF-connection and flushing port

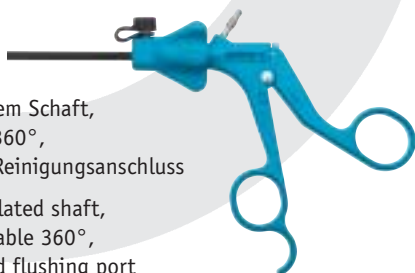







Z.0005.02

PEEK-Multifunktionsgriff mit
isoliertem Schaft, drehbar 360°,
mit HF-Anschluss und Reinigungsanschluss

PEEK-Multifunction handle
insulated shaft, rotatable 360°,
with HF-connection and flushing port



Einsatz allein Insert only	Instrument komplett / Instrument complete			
	Griff ohne Sperre Handle without ratchet	Multifunktionsgriff Multifunction handle		
Z.2940.60	Z.2940.01	Z.2940.02	Faßzange, 1:2 Zähne, doppelbeweglich Grasping forceps, 1:2 teeth, double action	 2/3
Z.2941.60	Z.2941.01	Z.2941.02	Dissektionszange, nicht gezahnt, doppelbeweglich Dissecting forceps, not serrated, double action	 2/3
Z.2942.60	Z.2942.01	Z.2942.02	Gewebefaßzange, doppelbeweglich Grasping forceps, double action	 2/3
Z.2943.60	Z.2943.01	Z.2943.02	Faßzange, kräftig, ein Maulteil gefenestert, doppelbeweglich Grasping forceps, strong, one jaw part fenestrated, double action	 2/3
Z.2944.60	Z.2944.01	Z.2944.02	Faßzange, atraumatisch, doppelbeweglich Grasping forceps, atraumatic, double action	 2/3
Z.2945.60	Z.2945.01	Z.2945.02	Faßzange, doppelbeweglich Grasping forceps, double action	 2/3
Z.2946.60	Z.2946.01	Z.2946.02	Darmgreifer, doppelbeweglich Bowel forceps, double action	 2/3

Faßzangen und Dissektionszangen, Ø 5 mm, 33 cm, dreh- und zerlegbar, mit Reinigungsanschluss

Grasping and dissecting forceps, Ø 5 mm, 33 cm, rotatable and detachable, with flushing port









Z.0005.01
PEEK-Griff mit isoliertem Schaft, **ohne Sperre**, drehbar 360°, mit HF-Anschluss und Reinigungsanschluss
PEEK-handle with insulated shaft, **without ratchet**, rotatable 360°, with HF-connection and flushing port



Z.0005.02
PEEK-Multifunktionsgriff mit isoliertem Schaft, drehbar 360°, mit HF-Anschluss und Reinigungsanschluss
PEEK-Multifunction handle insulated shaft, rotatable 360°, with HF-connection and flushing port



Einsatz allein Insert only	Instrument komplett / Instrument complete			
	Griff ohne Sperre Handle without ratchet	Multifunktionsgriff Multifunction handle		
Z.2947.60	Z.2947.01	Z.2947.02	Tubenfaßzange, doppelbeweglich Tube grasping forceps, double action	 2/3
Z.4435.60	Z.4435.01	Z.4435.02	Präparier- und Faßzange, stumpf, mit Löffel, doppelbeweglich Dissecting and grasping forceps, blunt, with spoon, double action	 2/3
Z.4035.60	Z.4035.01	Z.4035.02	HEAVY DUTY (FUNDUS) Faßzange, doppelbeweglich HEAVY DUTY (FUNDUS) grasping forceps, double action	 2/3
Z.4135.60	Z.4135.01	Z.4135.02	Alligator Faßzange, doppelbeweglich Alligator grasping forceps, double action	 2/3
Z.2948.60	Z.2948.01	Z.2948.02	BABCOCK Faßzange, kreuzverzahnt BABCOCK grasping forceps, cross serrated	 2/3
Z.4535.60	Z.4535.01	Z.4535.02	BABCOCK Faßzange, Maullänge 30 mm, doppelbeweglich BABCOCK grasping forceps, jaw length 30 mm, double action	 2/3

**Faßzangen und Dissektionszangen, Ø 5 mm, 33 cm,
dreh- und zerlegbar, mit Reinigungsanschluss**

**Grasping and dissecting forceps, Ø 5 mm, 33 cm,
rotatable and detachable, with flushing port**



Z.0005.01

PEEK-Griff mit isoliertem Schaft, **ohne Sperre**, drehbar 360°, mit HF-Anschluss und Reinigungsanschluss

PEEK-handle with insulated shaft, **without ratchet**, rotatable 360°, with HF-connection and flushing port

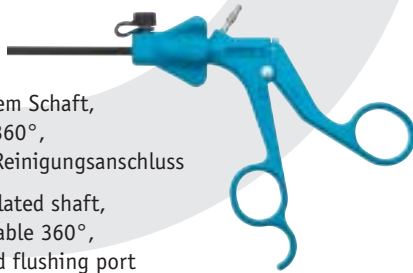







Z.0005.02

PEEK-Multifunktionsgriff mit isoliertem Schaft, drehbar 360°, mit HF-Anschluss und Reinigungsanschluss

PEEK-Multifunction handle insulated shaft, rotatable 360°, with HF-connection and flushing port



Einsatz allein Insert only	Instrument komplett / Instrument complete			
	Griff ohne Sperre Handle without ratchet	Multifunktionsgriff Multifunction handle		
Z.2933.60	Z.2933.01	Z.2933.02	Dissektor doppelbeweglich, flach Dissecting forceps, double action, flat	 2/3
Z.2934.60	Z.2934.01	Z.2934.02	Dissektor, feines Modell, flach Dissecting forceps, delicate pattern, flat	 2/3
Z.2935.60	Z.2935.01	Z.2935.02	SCHERTL Faßzange, gefenestert, doppelbeweglich SCHERTL grasping forceps, fenestrated, double action	 2/3
Z.2952.60	Z.2952.01	Z.2952.02	MICHEL atraumatische Faßzange MICHEL atraumatic dissecting forceps	 2/3
Z.2953.60	Z.2953.01	Z.2953.02	MICHEL atraumatische Faßzange, doppelbeweglich MICHEL atraumatic dissecting forceps, double action	 2/3
Z.2237.60	Z.2237.01	Z.2237.02	Hartmetall Faßzange, doppelbeweglich Grasping forceps with tungsten inserts, double action	 2/3
Z.2932.60	Z.2932.01	Z.2932.02	Mikro Faßzange Micro grasping forceps	 2/3

Faßzangen und Dissektionszangen, Ø 5 mm, 33 cm, dreh- und zerlegbar, mit Reinigungsanschluss

Grasping and dissecting forceps, Ø 5 mm, 33 cm, rotatable and detachable, with flushing port



Z.0005.01

PEEK-Griff mit isoliertem Schaft, **ohne Sperre**, drehbar 360°, mit HF-Anschluss und Reinigungsanschluss

PEEK-handle with insulated shaft, **without ratchet**, rotatable 360°, with HF-connection and flushing port

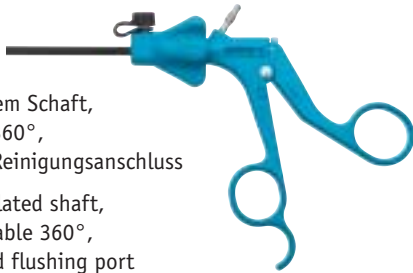





Z.0005.02

PEEK-Multifunktionsgriff mit isoliertem Schaft, drehbar 360°, mit HF-Anschluss und Reinigungsanschluss

PEEK-Multifunction handle insulated shaft, rotatable 360°, with HF-connection and flushing port



Einsatz allein Insert only	Instrument komplett / Instrument complete		
	Griff ohne Sperre Handle without ratchet	Multifunktionsgriff Multifunction handle	
Z.1635.60	Z.1635.01	Z.1635.02	DORSEY Darmklemme, Mauillänge 40 mm, doppelbeweglich DORSEY intestinal forceps, jaw length 40 mm, double action 
Z.1335.60	Z.1335.01	Z.1335.02	Krallengreifer Claw grasping forceps 
Z.2949.60	Z.2949.01	Z.2949.02	ALLIS Faßzange, Mauillänge 30 mm, doppelbeweglich ALLIS grasping forceps, jaw length 30 mm, double action 
Z.2950.60	Z.2950.01	Z.2950.02	HUNTER BOWEL Faßzange, doppelbeweglich HUNTER BOWEL grasping forceps, double action 
Z.3035.60	Z.3035.01	Z.3035.02	DEBAKEY Faßzange, Mauillänge 30 mm, doppelbeweglich DEBAKEY grasping forceps, jaw length 30 mm, double action 

**Biopsiezangen, Ø 5 mm, 33 cm,
dreh- und zerlegbar, mit Reinigungsanschluss**

**Biopsy forceps, Ø 5 mm, 33 cm,
rotatable and detachable, with flushing port**



Z.0005.01

PEEK-Griff mit isoliertem Schaft,
ohne Sperre, drehbar 360°,
mit HF-Anschluss und Reinigungsanschluss

PEEK-handle with insulated shaft,
without ratchet, rotatable 360°,
with HF-connection and flushing port

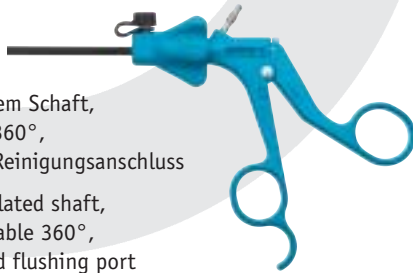

Z.0005.02

PEEK-Multifunktionsgriff mit
isoliertem Schaft, drehbar 360°,
mit HF-Anschluss und Reinigungsanschluss

PEEK-Multifunction handle
insulated shaft, rotatable 360°,
with HF-connection and flushing port



Einsatz allein Insert only	Instrument komplett / Instrument complete			
	Griff ohne Sperre Handle without ratchet	Multifunktionsgriff Multifunction handle		
Z.3135.60	Z.3135.01	Z.3135.02	Biopsie- und Faßzange, doppelbeweglich Biopsy and grasping forceps, double action	 2/3
Z.3235.60	Z.3235.01	Z.3235.02	Biopsiezange, Löffelmaul mit Dorn, doppelbeweglich Biopsy forceps, spoon jaw with needle, double action	 2/3
Z.3335.60	Z.3335.01	Z.3335.02	Biopsiezange, Löffelmaul, doppelbeweglich Biopsy forceps, spoon jaw, double action	 2/3
Z.4235.60	Z.4235.01	Z.4235.02	Biopsiezange, Löffelmaul mit Dorn Biopsy forceps, spoon jaw with needle	 2/3
Z.4237.60	Z.4237.01	Z.4237.02	Biopsiezange, Löffelmaul Biopsy forceps, spoon jaw	 2/3

Biopsiezangen, Ø 5 mm, 33 cm, dreh- und zerlegbar, mit Reinigungsanschluss

Biopsy forceps, Ø 5 mm, 33 cm, rotatable and detachable, with flushing port



Z.0005.01

PEEK-Griff mit isoliertem Schaft,
ohne Sperre, drehbar 360°,
mit HF-Anschluss und Reinigungsanschluss

PEEK-handle with insulated shaft,
without ratchet, rotatable 360°,
with HF-connection and flushing port

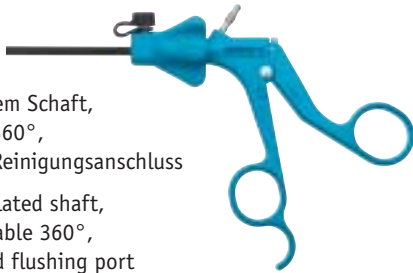





Z.0005.02

PEEK-Multifunktionsgriff mit
isoliertem Schaft, drehbar 360°,
mit HF-Anschluss und Reinigungsanschluss

PEEK-Multifunction handle
insulated shaft, rotatable 360°,
with HF-connection and flushing port



Einsatz allein Insert only	Instrument komplett / Instrument complete			
	Griff ohne Sperre Handle without ratchet	Multifunktionsgriff Multifunction handle		
Z.3435.60	Z.3435.01	Z.3435.02	BLAKESLEY Biopsiezange BLAKESLEY Biopsy forceps	 2/3
Z.3535.60	Z.3535.01	Z.3535.02	Biopsiezange, durchschneidend Biopsy forceps, cut through type	 2/3
Z.3536.60	Z.3536.01	Z.3536.02	FRANGENHEIM Biopsiezange, durchschneidend FRANGENHEIM biopsy forceps, cut through type	 2/3
Z.3537.60	Z.3537.01	Z.3537.02	Mini-Biopsiezange, Löffelmaul Mini biopsy forceps, spoon jaw	 2/3

**Scheren, Ø 5 mm, 33 cm,
dreh- und zerlegbar, mit Reinigungsanschluss**

**Scissors, Ø 5 mm, 33 cm,
rotatable and detachable, with flushing port**



Z.0005.01

PEEK-Griff mit isoliertem Schaft, ohne Sperre, drehbar 360°, mit HF-Anschluss und Reinigungsanschluss

PEEK-handle with insulated shaft, without ratchet, rotatable 360°, with HF-connection and flushing port

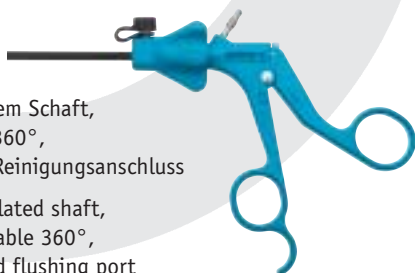





Z.0005.02

PEEK-Multifunktionsgriff mit isoliertem Schaft, drehbar 360°, mit HF-Anschluss und Reinigungsanschluss

PEEK-Multifunction handle insulated shaft, rotatable 360°, with HF-connection and flushing port



Einsatz allein Insert only	Instrument komplett / Instrument complete			
	Griff ohne Sperre Handle without ratchet	Multifunktionsgriff Multifunction handle		
Z.5235.60	Z.5235.01	-	Peritonealschere, gezahnt, stumpf, gerade Peritoneal scissors, serrated, blunt, straight	 2/3
Z.5335.60	Z.5335.01	-	Peritonealschere, gezahnt, spitz, gerade Peritoneal scissors, serrated, tips pointed, straight	 2/3
Z.5435.60	Z.5435.01	-	Hakenschere Hook scissors	 2/3
Z.5436.60	Z.5436.01	-	MINI - Hakenschere MINI - hook scissors	 2/3
Z.5535.60	Z.5535.01	-	METZENBAUM Schere, gerade, doppelbeweglich METZENBAUM scissors, straight, double action	 2/3
Z.5536.60	Z.5536.01	-	METZENBAUM ENDO-Schere, stark gebogen, doppelbeweglich METZENBAUM ENDO-scissors, curved strongly, double action	 2/3
Z.5635.60	Z.5635.01	-	METZENBAUM Schere, leicht gebogen, doppelbeweglich METZENBAUM scissors, curved slightly, double action	 2/3

Scheren, Ø 5 mm, 33 cm, dreh- und zerlegbar, mit Reinigungsanschluss

Scissors, Ø 5 mm, 33 cm, rotatable and detachable, with flushing port



Z.0005.01

PEEK-Griff mit isoliertem Schaft,
ohne Sperre, drehbar 360°,
mit HF-Anschluss und Reinigungsanschluss

PEEK-handle with insulated shaft,
without ratchet, rotatable 360°,
with HF-connection and flushing port

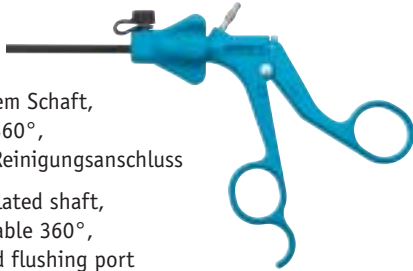







Z.0005.02

PEEK-Multifunktionsgriff mit
isoliertem Schaft, drehbar 360°,
mit HF-Anschluss und Reinigungsanschluss

PEEK-Multifunction handle
insulated shaft, rotatable 360°,
with HF-connection and flushing port



Einsatz allein Insert only	Instrument komplett / Instrument complete			
	Griff ohne Sperre Handle without ratchet	Multifunktionsgriff Multifunction handle		
Z.5634.60 L	Z.5634.01 L	-	METZENBAUM Schere, gerade, langes Blatt, doppelbeweglich METZENBAUM scissors, straight, long blade, double action	 2/3
Z.5635.60 L	Z.5635.01 L	-	METZENBAUM Schere, gebogen, langes Blatt, doppelbeweglich METZENBAUM scissors, curved, long blade, double action	 2/3
Z.5635.60 LZ	Z.5635.01 LZ	-	METZENBAUM Schere, gebogen, gezahnt, langes Blatt, doppelbeweglich METZENBAUM scissors, curved, serrated, long blade, double action	 2/3
Z.5240.60	Z.5240.01	-	BABY - METZENBAUM Schere, gebogen, doppelbeweglich BABY - METZENBAUM scissors, curved, double action	 2/3
Z.5238.60	Z.5238.01	-	METZENBAUM Schere, gerade, kurz, spitz, doppelbeweglich METZENBAUM scissors, straight, short, pointed, double action	 2/3
Z.5239.60	Z.5239.01	-	MINI-METZENBAUM Schere, gebogen, doppelbeweglich MINI-METZENBAUM scissors, curved, double action	 2/3
Z.5239.60 Z	Z.5239.01 Z	-	MINI-METZENBAUM Schere, gezahnt, gebogen, doppelbeweglich MINI-METZENBAUM scissors, serrated, curved, double action	 2/3

**Scheren, Ø 5 mm, 33 cm,
dreh- und zerlegbar, mit Reinigungsanschluss**

**Scissors, Ø 5 mm, 33 cm,
rotatable and detachable, with flushing port**



Z.0005.01

PEEK-Griff mit isoliertem Schaft, ohne Sperre, drehbar 360°, mit HF-Anschluss und Reinigungsanschluss

PEEK-handle with insulated shaft, without ratchet, rotatable 360°, with HF-connection and flushing port

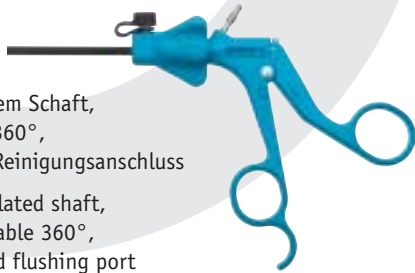



Z.0005.02

PEEK-Multifunktionsgriff mit isoliertem Schaft, drehbar 360°, mit HF-Anschluss und Reinigungsanschluss

PEEK-Multifunction handle insulated shaft, rotatable 360°, with HF-connection and flushing port



Einsatz allein Insert only	Instrument komplett / Instrument complete			
	Griff ohne Sperre Handle without ratchet	Multifunktionsgriff Multifunction handle		
Z.5242.60	Z.5242.01	-	Micro Schere, gerade, spitz Micro scissors, straight, pointed	 2/3
Z.5243.60	Z.5243.01	-	Micro Schere, gebogen, spitz Micro scissors, curved, pointed	 2/3

Faßzangen, Ø 5 mm, 45 cm, dreh- und zerlegbar, mit Reinigungsanschluss

Grasping forceps, Ø 5 mm, 45 cm, rotatable and detachable, with flushing port



Z.0005.41

PEEK-Griff mit isoliertem Schaft,
ohne Sperre, drehbar 360°,
mit HF-Anschluss und Reinigungsanschluss

PEEK-handle with insulated shaft,
without ratchet, rotatable 360°,
with HF-connection and flushing port

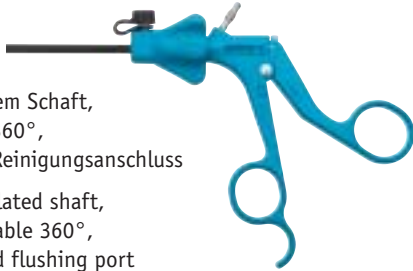

Z.0005.42

PEEK-Multifunktionsgriff mit
isoliertem Schaft, drehbar 360°,
mit HF-Anschluss und Reinigungsanschluss

PEEK-Multifunction handle
insulated shaft, rotatable 360°,
with HF-connection and flushing port



Einsatz allein Insert only	Instrument komplett / Instrument complete			
	Griff ohne Sperre Handle without ratchet	Multifunktionsgriff Multifunction handle		
Z.6045.60	Z.6045.01	Z.6045.02	ALLIS Faßzange ALLIS grasping forceps	 2/3
Z.6145.60	Z.6145.01	Z.6145.02	Faßzange, 1x2 Zähne Grasping forceps, 1x2 teeth	 2/3
Z.6245.60	Z.6245.01	Z.6245.02	COBRA Faßzange COBRA grasping forceps	 2/3
Z.6345.60	Z.6345.01	Z.6345.02	NEEDLE NOSE Faßzange, feines Maul NEEDLE NOSE grasping forceps, delicate jaws	 2/3
Z.7245.60	Z.7245.01	Z.7245.02	KELLY Faßzange, doppelbeweglich KELLY grasping forceps, double action	 2/3
Z.1645.60	Z.1645.01	Z.1645.02	DORSEY Darmklemme, Maullänge 40 mm, doppelbeweglich DORSEY intestinal forceps, jaw length 40 mm, double action	 2/3
Z.6535.60	Z.6535.01	Z.6535.02	MARYLAND Dissektor, leicht gebogen, doppelbeweglich MARYLAND dissecting forceps, curved slightly, double action	 2/3

**Faßzangen, Ø 5 mm, 45 cm,
dreh- und zerlegbar, mit Reinigungsanschluss**

**Grasping forceps, Ø 5 mm, 45 cm,
rotatable and detachable, with flushing port**



Z.0005.41

PEEK-Griff mit isoliertem Schaft, ohne Sperre, drehbar 360°, mit HF-Anschluss und Reinigungsanschluss

PEEK-handle with insulated shaft, without ratchet, rotatable 360°, with HF-connection and flushing port

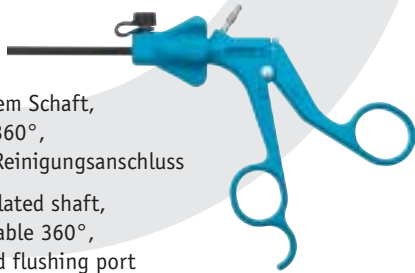







Z.0005.42

PEEK-Multifunktionsgriff mit isoliertem Schaft, drehbar 360°, mit HF-Anschluss und Reinigungsanschluss

PEEK-Multifunction handle insulated shaft, rotatable 360°, with HF-connection and flushing port



Einsatz allein Insert only	Instrument komplett / Instrument complete			
	Griff ohne Sperre Handle without ratchet	Multifunktionsgriff Multifunction handle		
Z.1638.60	Z.1638.01	Z.1638.02	MIXTER Dissektionszange, 90° abgewinkelt, doppelbeweglich MIXTER dissecting forceps, 90° angled, double action	 2/3
Z.3052.60	Z.3052.01	Z.3052.02	MICHEL atraumatische Faßzange MICHEL atraumatic dissecting forceps	 2/3
Z.4536.60	Z.4536.01	Z.4536.02	BABCOCK Faßzange, Maullänge 30 mm, doppelbeweglich BABCOCK grasping forceps, jaw length 30 mm, double action	 2/3
Z.4735.60	Z.4735.01	Z.4735.02	HEAVY DUTY (FUNDUS) Faßzange, doppelbeweglich HEAVY DUTY (FUNDUS) grasping forceps, double action	 2/3
Z.4944.60	Z.4944.01	Z.4944.02	Faßzange, atraumatisch, doppelbeweglich Grasping forceps, atraumatic, double action	 2/3
Z.6835.60	Z.6835.01	Z.6835.02	DUCK BILL Präparier- und Faßzange DUCK BILL dissecting and grasping forceps	 2/3
Z.6836.60	Z.6836.01	Z.6836.02	CLEEVE DUCK BILL Präparier- und Faßzange, doppelbeweglich CLEEVE DUCK BILL dissecting and grasping forceps, double action	 2/3

Faßzangen und Scheren, Ø 5 mm, 45 cm, dreh- und zerlegbar, mit Reinigungsanschluss

Grasping forceps and scissors, Ø 5 mm, 45 cm, rotatable and detachable, with flushing port



Z.0005.41

PEEK-Griff mit isoliertem Schaft,
ohne Sperre, drehbar 360°,
mit HF-Anschluss und Reinigungsanschluss

PEEK-handle with insulated shaft,
without ratchet, rotatable 360°,
with HF-connection and flushing port

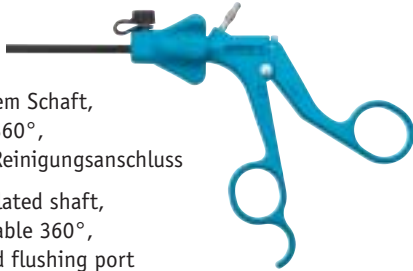







Z.0005.42

PEEK-Multifunktionsgriff mit
isoliertem Schaft, drehbar 360°,
mit HF-Anschluss und Reinigungsanschluss

PEEK-Multifunction handle
insulated shaft, rotatable 360°,
with HF-connection and flushing port



Einsatz allein Insert only	Instrument komplett / Instrument complete			
	Griff ohne Sperre Handle without ratchet	Multifunktionsgriff Multifunction handle		
Z.2954.60	Z.2954.01	Z.2954.02	MIXTER Dissektionszange, 90° abgewinkelt, doppelbeweglich MIXTER dissecting forceps, 90° angled, double action	 2/3
Z.6945.60	Z.6945.01	Z.6945.02	MICHEL atraumatische Faßzange MICHEL atraumatic dissecting forceps	 2/3
Z.6445.60	Z.6445.01	-	BABCOCK Faßzange, Maullänge 30 mm, doppelbeweglich BABCOCK grasping forceps, jaw length 30 mm, double action	 2/3
Z.6545.60	Z.6545.01	-	HEAVY DUTY (FUNDUS) Faßzange, doppelbeweglich HEAVY DUTY (FUNDUS) grasping forceps, double action	 2/3
Z.7045.60	Z.7045.01	-	Faßzange, atraumatisch, doppelbeweglich Grasping forceps, atraumatic, double action	 2/3
Z.5735.60	Z.5735.01	-	Peritonealschere, gezahnt, spitz, gerade Peritoneal scissors, serrated, tips pointed, straight	 2/3

**Biopsiezangen, Ø 5 mm, 45 cm,
dreh- und zerlegbar, mit Reinigungsanschluss**

**Biopsy forceps, Ø 5 mm, 45 cm,
rotatable and detachable, with flushing port**



Z.0005.41

PEEK-Griff mit isoliertem Schaft,
ohne Sperre, drehbar 360°,
mit HF-Anschluss und Reinigungsanschluss

PEEK-handle with insulated shaft,
without ratchet, rotatable 360°,
with HF-connection and flushing port

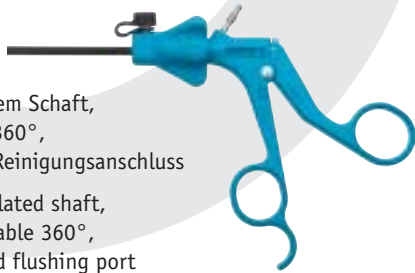



Z.0005.42

PEEK-Multifunktionsgriff mit
isoliertem Schaft, drehbar 360°,
mit HF-Anschluss und Reinigungsanschluss

PEEK-Multifunction handle
insulated shaft, rotatable 360°,
with HF-connection and flushing port



Einsatz allein Insert only	Instrument komplett / Instrument complete			
	Griff ohne Sperre Handle without ratchet	Multifunktionsgriff Multifunction handle		
Z.6645.60	Z.6645.01	Z.6645.02	BLAKESLEY Biopsiezange BLAKESLEY biopsy forceps	 2/3
Z.6745.60	Z.6745.01	Z.6745.02	Biopsiezange, durchschneidend Biopsy forceps, cut through type	 2/3
Z.7145.60	Z.7145.01	Z.7145.02	FRANGENHEIM Biopsiezange, durchschneidend FRANGENHEIM biopsy forceps, cut through type	 2/3

Faßzangen und Scheren, Ø 10 mm, 33 cm, dreh- und zerlegbar, mit Reinigungsanschluss

Grasping forceps and scissors, Ø 10 mm, 33 cm, rotatable and detachable, with flushing port



Z.0010.01

PEEK-Griff mit isoliertem Schaft, **ohne Sperre**, drehbar 360°, mit HF-Anschluss und Reinigungsanschluss

PEEK-handle with insulated shaft, **without ratchet**, rotatable 360°, with HF-connection and flushing port

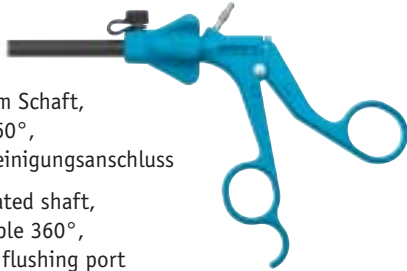

Z.0010.02

PEEK-Multifunktionsgriff mit isoliertem Schaft, drehbar 360°, mit HF-Anschluss und Reinigungsanschluss

PEEK-Multifunction handle insulated shaft, rotatable 360°, with HF-connection and flushing port



Einsatz allein Insert only	Instrument komplett / Instrument complete			
	Griff ohne Sperre Handle without ratchet	Multifunktionsgriff Multifunction handle		
Z.0520.60	Z.0520.01	Z.0520.02	Krallengreifer Claw grasping forceps	 2/3
Z.0522.60	Z.0522.01	Z.0522.02	Krallengreifer, doppelbeweglich Claw grasping forceps, double action	 2/3
Z.0515.60	Z.0515.01	-	OP-Schere OR scissors	 2/3
Z.0510.60	Z.0510.01	Z.0510.02	OP-Löffelzange OR spoon forceps	 2/3

**Faßzangen, Ø 10 mm, 33 cm,
dreh- und zerlegbar, mit Reinigungsanschluss**

**Grasping forceps, Ø 10 mm, 33 cm,
rotatable and detachable, with flushing port**



Z.0010.01

PEEK-Griff mit isoliertem Schaft,
ohne Sperre, drehbar 360°,
mit HF-Anschluss und Reinigungsanschluss

PEEK-handle with insulated shaft,
without ratchet, rotatable 360°,
with HF-connection and flushing port

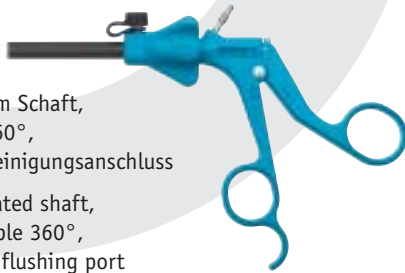

Z.0010.02

PEEK-Multifunktionsgriff mit
isoliertem Schaft, drehbar 360°,
mit HF-Anschluss und Reinigungsanschluss

PEEK-Multifunction handle
insulated shaft, rotatable 360°,
with HF-connection and flushing port



Einsatz allein Insert only	Instrument komplett / Instrument complete		
	Griff ohne Sperre Handle without ratchet	Multifunktionsgriff Multifunction handle	
Z.0530.60	Z.0530.01	Z.0530.02	<p>ALLIS Faßzange, doppelbeweglich</p> <p>ALLIS grasping forceps, double action</p> <p style="text-align: right;">2/3</p>
Z.0531.60	Z.0531.01	Z.0531.02	<p>DUVAL Faßzange, doppelbeweglich</p> <p>DUVAL grasping forceps, double action</p> <p style="text-align: right;">2/3</p>
Z.0532.60	Z.0532.01	Z.0532.02	<p>BABCOCK Faßzange, doppelbeweglich</p> <p>BABCOCK grasping forceps, double action</p> <p style="text-align: right;">2/3</p>
Z.0533.60	Z.0533.01	Z.0533.02	<p>MARC Faßzange, doppelbeweglich</p> <p>MARC grasping forceps, double action</p> <p style="text-align: right;">2/3</p>

Faßzangen, Ø 10 mm, 33 cm, dreh- und zerlegbar, mit Reinigungsanschluss

Grasping forceps, Ø 10 mm, 33 cm, rotatable and detachable, with flushing port



Z.0010.01

PEEK-Griff mit isoliertem Schaft,
ohne Sperre, drehbar 360°,
mit HF-Anschluss und Reinigungsanschluss

PEEK-handle with insulated shaft,
without ratchet, rotatable 360°,
with HF-connection and flushing port

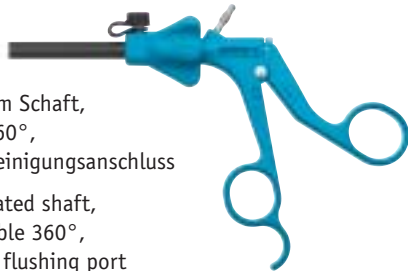

Z.0010.02

PEEK-Multifunktionsgriff mit
isoliertem Schaft, drehbar 360°,
mit HF-Anschluss und Reinigungsanschluss

PEEK-Multifunction handle
insulated shaft, rotatable 360°,
with HF-connection and flushing port



Einsatz allein Insert only	Instrument komplett / Instrument complete		
	Griff ohne Sperre Handle without ratchet	Multifunktionsgriff Multifunction handle	
Z.0534.60	Z.0534.01	Z.0534.02	<p>PENNINGTON Faßzange, doppelbeweglich</p> <p>PENNINGTON grasping forceps, double action</p> 
Z.0535.60	Z.0535.01	Z.0535.02	<p>DEBAKEY Darmklemme, Maullänge 40 mm, doppelbeweglich</p> <p>DEBAKEY intestinal forceps, jaw length 40 mm, double action</p> 
Z.0537.60	Z.0537.01	Z.0537.02	<p>KOELN Faßzange, doppelbeweglich</p> <p>KOELN grasping forceps, double action</p> 
Z.0541.60	Z.0541.01	Z.0541.02	<p>ALLIGATOR Faßzange, doppelbeweglich</p> <p>ALLIGATOR grasping forceps, double action</p> 

**Dissektions- und Faßzangen, Ø 10 mm, 33 cm,
dreh- und zerlegbar, mit Reinigungsanschluss**

**Dissecting and grasping forceps, Ø 10 mm, 33 cm,
rotatable and detachable, with flushing port**



Z.0010.01

PEEK-Griff mit isoliertem Schaft,
ohne Sperre, drehbar 360°,
mit HF-Anschluss und Reinigungsanschluss

PEEK-handle with insulated shaft,
without ratchet, rotatable 360°,
with HF-connection and flushing port

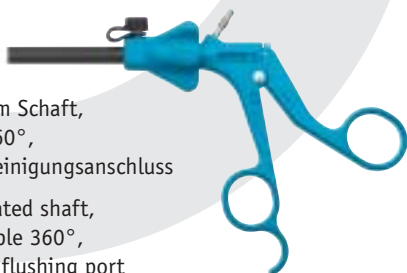



Z.0010.02

PEEK-Multifunktionsgriff mit
isoliertem Schaft, drehbar 360°,
mit HF-Anschluss und Reinigungsanschluss

PEEK-Multifunction handle
insulated shaft, rotatable 360°,
with HF-connection and flushing port

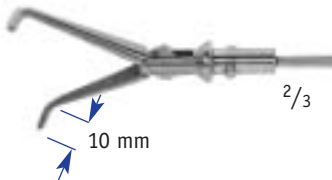

Einsatz allein Insert only	Instrument komplett / Instrument complete			
	Griff ohne Sperre Handle without ratchet	Multifunktionsgriff Multifunction handle		
Z.0542.60	Z.0542.01	Z.0542.02	PADDLE BABCOCK Faßzange, doppelbeweglich PADDLE BABCOCK grasping forceps, double action	 2/3
Z.0559.60	Z.0559.01	Z.0559.02	MIXTER Dissektionszange, 90° abgewinkelt, doppelbeweglich MIXTER dissecting forceps, 90° angled, double action	 2/3
Z.0560.60	Z.0560.01	Z.0560.02	MARYLAND Dissektor, leicht gebogen, doppelbeweglich MARYLAND dissecting forceps, curved slightly, double action	 2/3
Z.0561.60	Z.0561.01	Z.0561.02	MARYLAND Dissektor, stark gebogen, doppelbeweglich MARYLAND dissecting forceps, curved strongly, double action	 2/3

Cholangiographie Fixierzange, Krallengreifer, Ø 5 mm
Cholangiography fixation forceps, claw forceps, Ø 5 mm

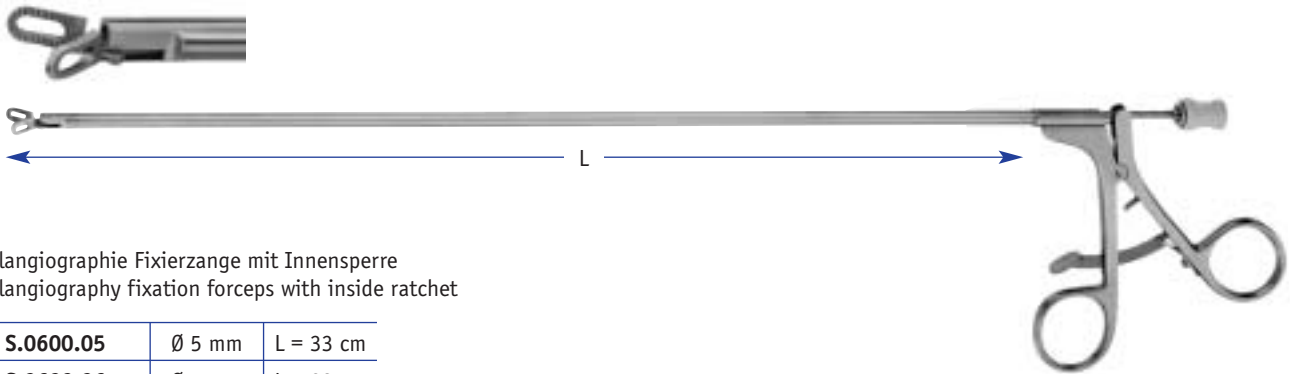

Cholangiographie Fixierzange mit Innensperre
 Cholangiography fixation forceps with inside ratchet

S.0600.05	Ø 5 mm	L = 33 cm
S.0600.06	Ø 5 mm	L = 28 cm

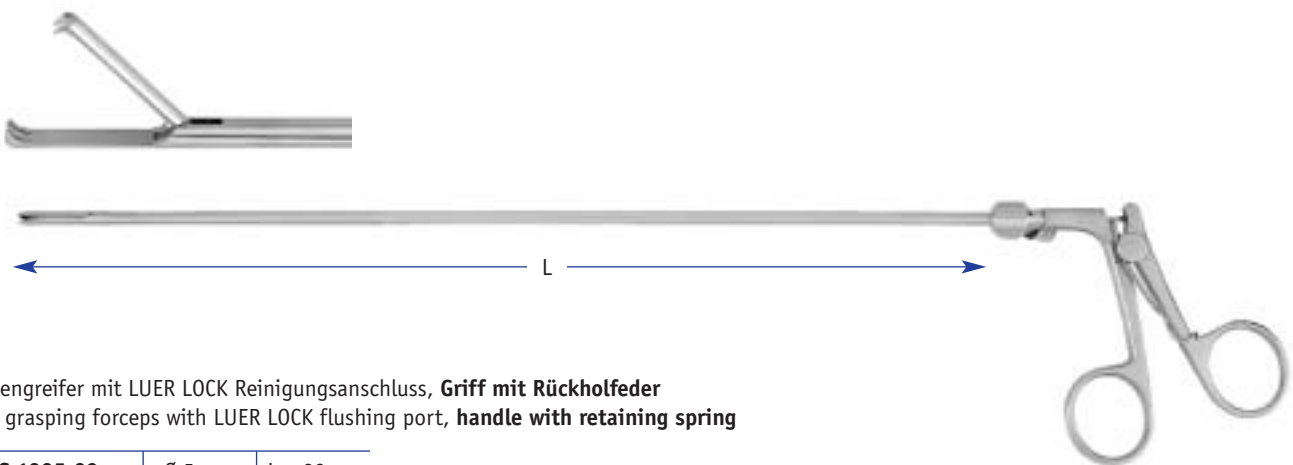

Krallengreifer mit LUER LOCK Reinigungsanschluss, **Griff mit Rückholfeder**
 Claw grasping forceps with LUER LOCK flushing port, **handle with retaining spring**

S.1335.20	Ø 5 mm	L = 33 cm
------------------	--------	-----------

Mikro Instrumente, Ø 5 mm, Länge 33 cm
Micro instruments, Ø 5 mm, length 33 cm

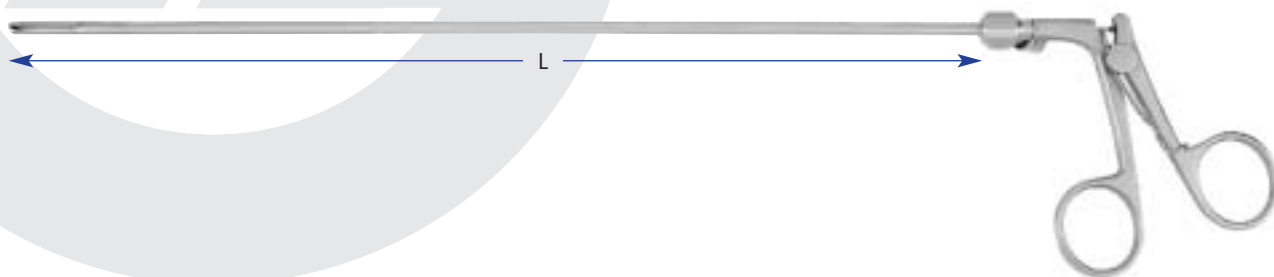

S.0552.01	Ø 5 mm	L = 33 cm	Mikro Faßzange, Griff mit Rückholfeder Micro grasping forceps, handle with retaining spring	
S.0553.01	Ø 5 mm	L = 33 cm	Mikro Faßzange, links gebogen, Griff mit Rückholfeder Micro grasping forceps, curved left, handle with retaining spring	
S.0554.01	Ø 5 mm	L = 33 cm	Mikro Biopsiezange, mit Löffel, Griff mit Rückholfeder Micro biopsy forceps, spoon shaped, handle with retaining spring	
S.0550.01	Ø 5 mm	L = 33 cm	Mikro Schere, gerade, Griff ohne Rückholfeder Micro scissors, straight, handle without retaining spring	
S.0551.01	Ø 5 mm	L = 33 cm	Mikro Schere, links gebogen, Griff ohne Rückholfeder Micro scissors, curved left, handle without retaining spring	

Instrumente - starre Ausführung, mit Reinigungsanschluss

Krallengreifer, Schere, Löffel, Ø 10 mm, Länge 33 cm

Instruments - rigid models, with flushing port

Claw forceps, scissors, spoons, Ø 10 mm, length 33 cm

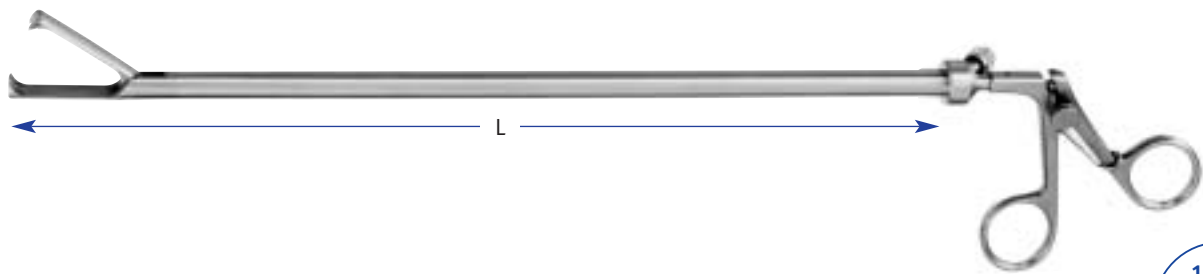

S.0520.20	Ø 10 mm	L = 33 cm	Krallengreifer, Griff mit Rückholfeder Claw grasping forceps, handle with retaining spring	
S.0515.20	Ø 10 mm	L = 33 cm	Schere, 1 Blatt gezahnt, Griff ohne Rückholfeder Scissors, 1 blade serrated, handle without retaining spring	
S.0510.20	Ø 10 mm	L = 33 cm	Löffelfaßzange, Griff mit Rückholfeder Spoon forceps, handle with retaining spring	

Mini-LAP Instrumente, Ø 3,4 mm, 30 cm , drehbar, mit Reinigungsanschluss
Mini-LAP instruments, Ø 3,4 mm, 30 cm, rotatable, with flushing port

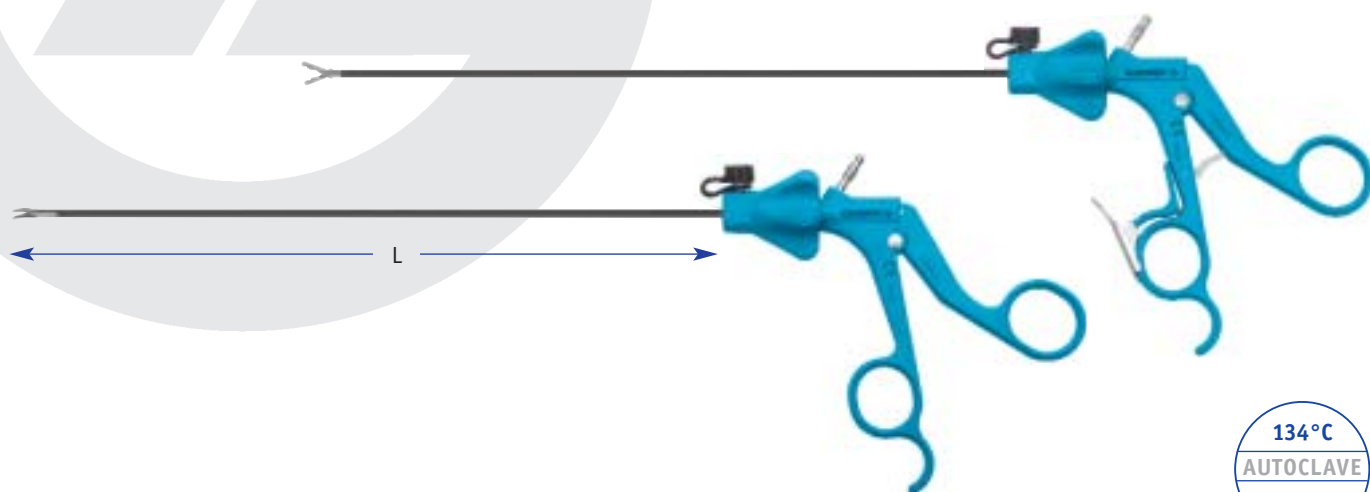



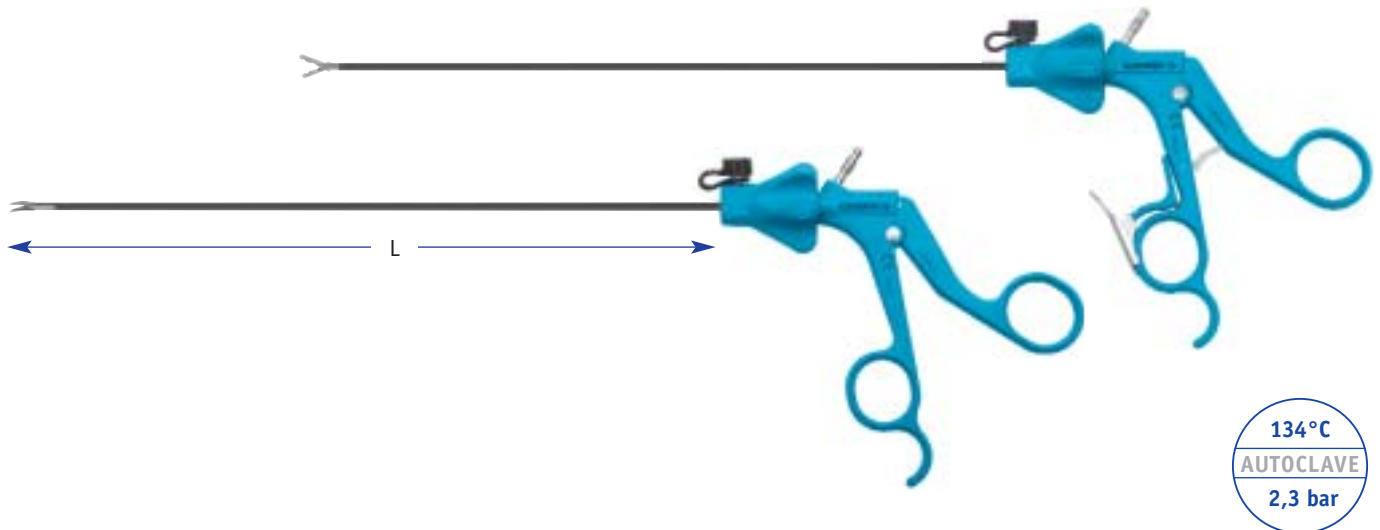

Z.0513.00	Ø 3,4 mm	L = 30 cm	Präparier- und Faßzange, stumpf, mit Löffel, doppelbeweglich, mit Sperre Dissecting and grasping forceps, blunt, with spoon, double action, with ratchet	
Z.0513.02	Ø 3,4 mm	L = 30 cm	Faßzange, mit Sperre doppelbeweglich, mit Sperre Grasping forceps, double action, with ratchet	
Z.0513.04	Ø 3,4 mm	L = 30 cm	Faßzange mit Zähnen, doppelbeweglich, mit Sperre Grasping forceps with teeth, double action, with ratchet	
Z.0513.06	Ø 3,4 mm	L = 30 cm	BABCOCK Faßzange, doppelbeweglich, mit Sperre BABCOCK grasping forceps, double action, with ratchet	
Z.0513.08	Ø 3,4 mm	L = 30 cm	HUNTER BOWEL Faßzange, doppelbeweglich, mit Sperre HUNTER BOWEL grasping forceps, double action, with ratchet	
Z.0513.10	Ø 3,4 mm	L = 30 cm	MIXTER Dissektionszange, 90° abgewinkelt, doppelbeweglich, ohne Sperre MIXTER dissecting forceps, 90° angled, double action, without ratchet	

Trokare zur Verwendung mit Mini-LAP Instrumenten siehe Seite 9-13
 Trocars for use with Mini-LAP instruments see page 9-13

Mini-LAP Instrumente, Ø 3,4 mm, 30 cm, drehbar, mit Reinigungsanschluss Mini-LAP instruments, Ø 3,4 mm, 30 cm, rotatable, with flushing port



Z.0513.12	Ø 3,4 mm	L = 30 cm	Faßzange, gefenstert, doppelbeweglich, delikates Modell, mit Sperre Grasping forceps, fenestrated, double action, delicate model, with ratchet	
Z.0513.14	Ø 3,4 mm	L = 30 cm	Faßzange, gefenstert, kräftig, doppelbeweglich, mit Sperre Grasping forceps, fenestrated, heavy pattern double action, with ratchet	
Z.0513.16	Ø 3,4 mm	L = 30 cm	MARYLAND Dissektor, leicht gebogen, doppelbeweglich, ohne Sperre MARYLAND dissecting forceps, curved slightly, double action, without ratchet	
Z.0513.18	Ø 3,4 mm	L = 30 cm	Faßzange, gefenstert, doppelbeweglich, mit Sperre Grasping forceps, fenestrated, double action, with ratchet	
Z.0513.20	Ø 3,4 mm	L = 30 cm	METZENBAUM ENDO-Schere, stark gebogen, doppelbeweglich, ohne Sperre METZENBAUM ENDO-scissors, curved strongly, double action, without ratchet	

Trokare zur Verwendung mit Mini-LAP Instrumenten siehe Seite 9-13
Trocars for use with Mini-LAP instruments see page 9-13

Clipanlagezangen, drehbar, Ø 10 mm
Clip appliers, rotatable, Ø 10 mm

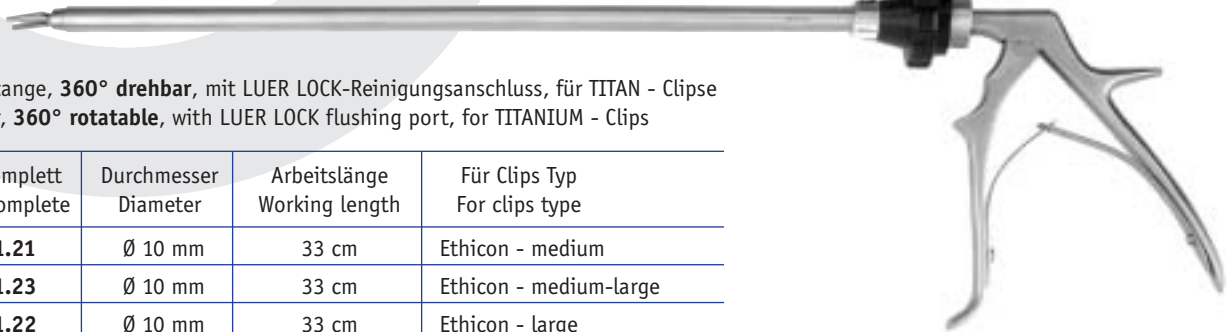

Clipanlagezange, **360° drehbar**, mit LUER LOCK-Reinigungsanschluss, für TITAN - Clipse
 Clip applier, **360° rotatable**, with LUER LOCK flushing port, for TITANIUM - Clips

Zange komplett Forceps complete	Durchmesser Diameter	Arbeitslänge Working length	Für Clips Typ For clips type
T.0611.21	Ø 10 mm	33 cm	Ethicon - medium
T.0611.23	Ø 10 mm	33 cm	Ethicon - medium-large
T.0611.22	Ø 10 mm	33 cm	Ethicon - large
T.0611.25	Ø 10 mm	33 cm	Pilling/Weck - medium
T.0611.26	Ø 10 mm	33 cm	Pilling/Weck - medium-large
T.0611.17	Ø 10 mm	33 cm	SLS - medium
T.0611.18	Ø 10 mm	33 cm	SLS - medium-large
T.0611.19	Ø 10 mm	33 cm	SLS - large
T.0611.46	Ø 10 mm	33 cm	HORIZON - medium
T.0611.47	Ø 10 mm	33 cm	HORIZON - medium-large
T.0611.48	Ø 10 mm	33 cm	HORIZON - large

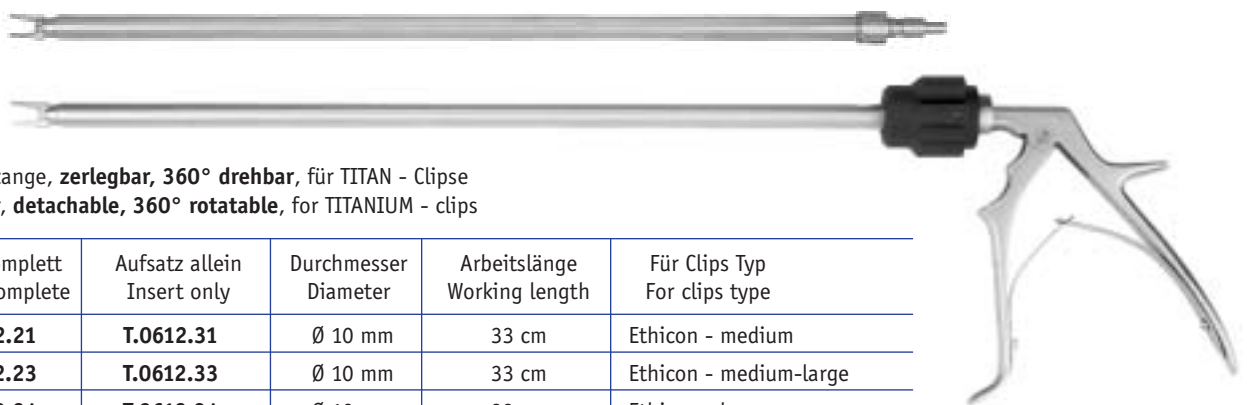

Clipanlagezange, **zerlegbar**, **360° drehbar**, für TITAN - Clipse
 Clip applier, **detachable**, **360° rotatable**, for TITANIUM - clips

Zange komplett Forceps complete	Aufsatz allein Insert only	Durchmesser Diameter	Arbeitslänge Working length	Für Clips Typ For clips type
T.0612.21	T.0612.31	Ø 10 mm	33 cm	Ethicon - medium
T.0612.23	T.0612.33	Ø 10 mm	33 cm	Ethicon - medium-large
T.0612.24	T.0612.34	Ø 10 mm	33 cm	Ethicon - large
T.0612.26	T.0612.36	Ø 10 mm	33 cm	Pilling/Weck - medium
T.0612.27	T.0612.37	Ø 10 mm	33 cm	Pilling/Weck - medium-large
T.0612.17	T.0612.38	Ø 10 mm	33 cm	SLS - medium
T.0612.18	T.0612.39	Ø 10 mm	33 cm	SLS - medium-large
T.0612.19	T.0612.40	Ø 10 mm	33 cm	SLS - large
T.0612.46	T.0612.41	Ø 10 mm	33 cm	HORIZON - medium
T.0612.47	T.0612.42	Ø 10 mm	33 cm	HORIZON - medium-large
T.0612.48	T.0612.43	Ø 10 mm	33 cm	HORIZON - large

**zerlegbar
detachable**

Clipanlegezangen Clip appliers



für medium Clipse bitte 6,5 mm Mehrfachfunktion Trokarhülse verwenden
for medium clips we recommend 6.5 mm multifunction trocar sleeves

Clipanlegezange, **zerlegbar, 360° drehbar**, für TITAN - Clipse
Clip applier, **detachable, 360° rotatable**, for TITANIUM - Clips

Zange komplett Forceps complete 25 cm	Aufsatz allein Insert only 33 cm	Durchmesser Diameter	Für Clips Typ For clips type
T.0608.10	T.0612.10	Ø 5 mm	Ethicon - small
T.0608.12	T.0612.12	Ø 5 mm	Ethicon - medium
T.0608.02	T.0612.02	Ø 5 mm	Pilling/Weck - small
T.0608.04	T.0612.04	Ø 5 mm	Pilling/Weck - medium
T.0608.16	T.0609.16	Ø 5 mm	SLS - small
T.0608.18	T.0609.18	Ø 5 mm	SLS - small-medium
T.0608.17	T.0609.17	Ø 5 mm	SLS - medium
T.0608.06	T.0612.06	Ø 5 mm	HOIRZON - medium
T.0608.08	T.0612.08	Ø 5 mm	HOIRZON - small



Aluminium Griff
Aluminium handle

Griff aus rostfreiem Stahl auf Anfrage
Stainless steel handle on request

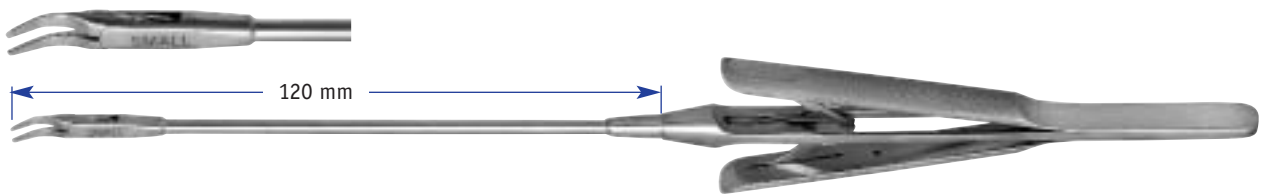

Clipanlegezange "Special" für VITALITEC, SLS Clipse
Clip applier "Special" for VITALITEC, SLS clips

Andere Fabrikate auf Anfrage
Other brands on request

für Clips Typ / for clips type	
T.0619.02	micro clips
T.0619.04	small clips
T.0619.06	small-medium clips
T.0619.08	medium clips

new

Clipanlegezange, für TITAN - Clipse,
Ethicon, HORIZON, Pilling/Weck, SLS, auf Anfrage

Clip applier, for TITANIUM - Clips,
Ethicon, HORIZON, Pilling/Weck, SLS, on request



ohne Abbildung / without illustration

T.0611.33	TITAN-Clips, E -medium-large, sterile Box (18 x 6 Stück / pieces)
T.0611.34	TITAN-Clips, PW -medium-large, sterile Box (16 x 10 Stück / pieces)

Nadelhalter
Needle holders

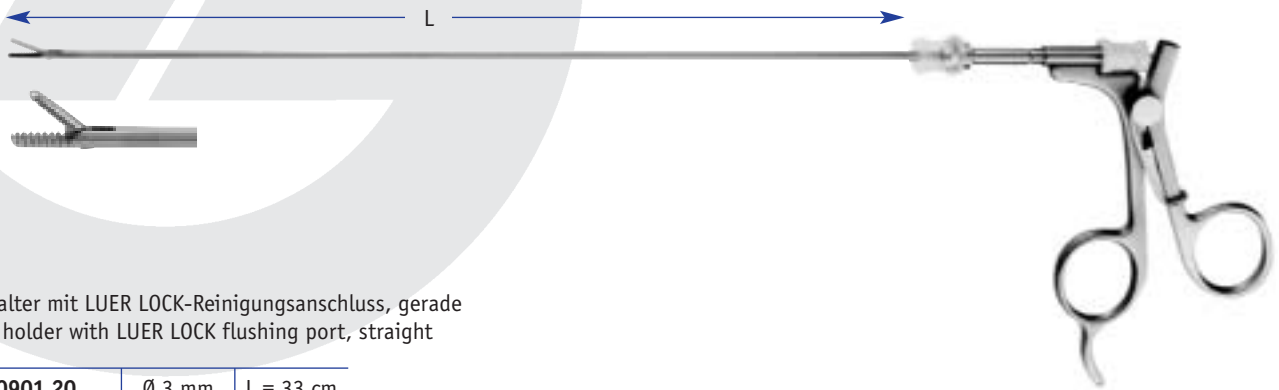

Nadelhalter mit LUER LOCK-Reinigungsanschluss, gerade
Needle holder with LUER LOCK flushing port, straight

S.0901.20	Ø 3 mm	L = 33 cm
------------------	--------	-----------

Applikator zur Verwendung mit 3 mm Nadelhalter S.0901.20
Applicator for use with 3 mm needle holder S.0901.20



S.0901.03

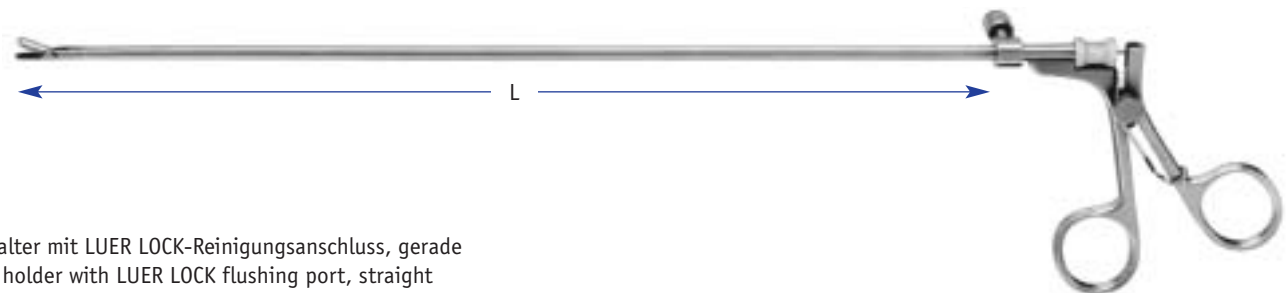

Nadelhalter mit LUER LOCK-Reinigungsanschluss, gerade
Needle holder with LUER LOCK flushing port, straight

S.0902.05	Ø 5 mm	L = 33 cm
------------------	--------	-----------

S.0902.06	Ø 5 mm	L = 33 cm	Hartmetall Nadelhalter Tungsten carbide needle holder
------------------	--------	-----------	--

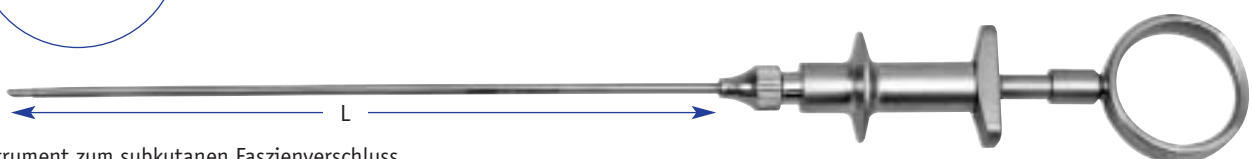
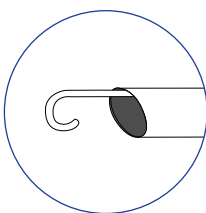

Nahtinstrument zum subkutanen Faszienschluss
Suture instrument for subcutaneous fascial closure

S.0904.07	Ø 2,1 mm	L = 14 cm
------------------	----------	-----------

Nadelhalter Needle holders

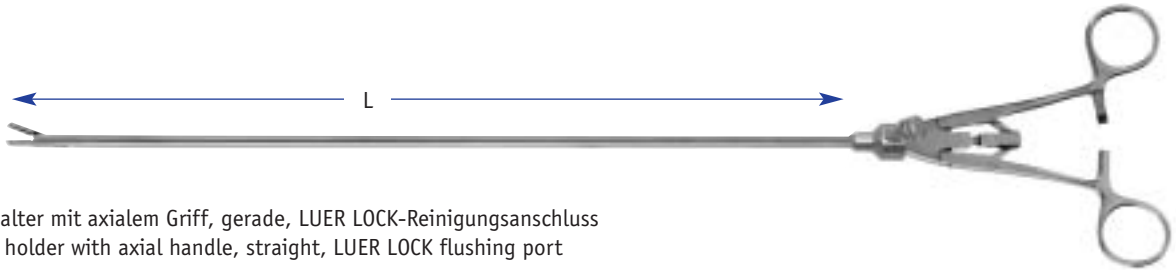

THOMAS Nadelhalter mit axialem Griff, gerade, LUER LOCK-Reinigungsanschluss
THOMAS needle holder with axial handle, straight, LUER LOCK flushing port

S.0902.16	Ø 5 mm	L = 33 cm		
S.0902.18	Ø 5 mm	L = 33 cm	mit Kunststoffschaft with plastic shaft	
S.0902.17	Ø 5 mm	L = 33 cm	Hartmetall Nadelhalter Tungsten carbide needle holder	
S.0902.19	Ø 5 mm	L = 33 cm	Hartmetall Nadelhalter mit Kunststoffschaft Tungsten carbide needle holder with plastic shaft	

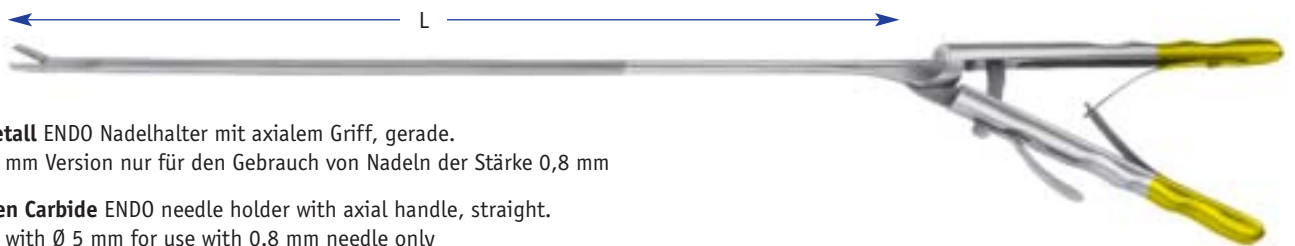

Hartmetall ENDO Nadelhalter mit axialem Griff, gerade.
Die Ø 5 mm Version nur für den Gebrauch von Nadeln der Stärke 0,8 mm

Tungsten Carbide ENDO needle holder with axial handle, straight.
Version with Ø 5 mm for use with 0.8 mm needle only

S.0903.18	Ø 5 mm	L = 33 cm		
S.0903.20	Ø 8 mm	L = 33 cm		



Hartmetall ENDO Nadelhalter mit axialem Griff, LUER LOCK-Reinigungsanschluss
Tungsten Carbide ENDO needle holder with axial handle, LUER LOCK flushing port

S.0906.33	Ø 5 mm	L = 33 cm	gerade straight	
S.0906.45	Ø 5 mm	L = 45 cm		
S.0907.33	Ø 5 mm	L = 33 cm	links gebogen curved left	
S.0907.45	Ø 5 mm	L = 45 cm		
S.0908.33	Ø 5 mm	L = 33 cm	konvex/konkav convex/concave	
S.0908.45	Ø 5 mm	L = 45 cm		

new

Nadelhalter Needle holders



S.0912.02	Ø 5 mm	L = 33 cm	<p>ENDO-Nadelhalter, mit 2-Branchen-Axialgriff, gerade LUER LOCK-Reinigungsanschluss</p> <p>ENDO needle holder, 2-branch axial handle, straight LUER LOCK flushing port</p>	
S.0912.04	Ø 5 mm	L = 33 cm	<p>Hartmetall ENDO-Nadelhalter, mit 2-Branchen-Axialgriff, gerade, LUER LOCK-Reinigungsanschluss</p> <p>Tungsten Carbide ENDO needle holder, 2-branch axial handle, straight, LUER LOCK flushing port</p>	
S.0912.06	Ø 5 mm	L = 33 cm	<p>Hartmetall ENDO-Nadelhalter, mit 2-Branchen-Axialgriff, gerade, LUER LOCK-Reinigungsanschluss</p> <p>Tungsten Carbide ENDO needle holder, 2-branch axial handle, straight, LUER LOCK flushing port</p>	
S.0912.08	Ø 5 mm	L = 33 cm	<p>Hartmetall ENDO-Nadelhalter, mit 2-Branchen-Axialgriff, rechts gebogen, LUER LOCK-Reinigungsanschluss</p> <p>Tungsten Carbide ENDO needle holder, 2-branch axial handle, curved right, LUER LOCK flushing port</p>	
S.0912.10	Ø 5 mm	L = 33 cm	<p>Hartmetall ENDO-Nadelhalter, mit 2-Branchen-Axialgriff, links gebogen, LUER LOCK-Reinigungsanschluss</p> <p>Tungsten Carbide ENDO needle holder, 2-branch axial handle, curved left, LUER LOCK flushing port</p>	
S.0912.12	Ø 5 mm	L = 33 cm	<p>Hartmetall ENDO-Gegennadelhalter, mit 2-Branchen-Axialgriff, LUER LOCK-Reinigungsanschluss</p> <p>Tungsten Carbide ENDO counter needle holder, 2-branch axial handle, LUER LOCK flushing port</p>	
S.0912.14	Ø 5 mm	L = 33 cm	<p>ENDO-Nadelhalter, Maulteile konvex/konkav beschichtet mit 2-Branchen-Axialgriff, LUER LOCK-Reinigungsanschluss</p> <p>ENDO needle holder, convex/concave jaws coated, 2-branch axial handle, LUER LOCK flushing port</p>	

Nadelhalter, zerlegbar Needle holders, detachable



Axialer Griff für Nadelhalteraufsätze,
mit Überlastungsschutz

Axial handle for needle holder tips,
with overstrain protection



S.0500.00

Hartmetall Nadelhalteraufsatz, mit LUER LOCK-Reinigungsanschluss
Tungsten carbide needle holder tip, with LUER LOCK flushing port



S.0500.01	Ø 5 mm	Hartmetall Nadelhalteraufsatz, gerade, mit LUER LOCK-Reinigungsanschluss Tungsten carbide needle holder tip, straight, with LUER LOCK flushing port	
S.0500.02	Ø 5 mm	Hartmetall Nadelhalteraufsatz, rechts gebogen, mit LUER LOCK-Reinigungsanschluss Tungsten carbide needle holder tip, curved right, with LUER LOCK flushing port	
S.0500.03	Ø 5 mm	Hartmetall Nadelhalteraufsatz, links gebogen, mit LUER LOCK-Reinigungsanschluss Tungsten carbide needle holder tip, curved left, with LUER LOCK flushing port	



Magnetstab
Magnetic rod



S.0900.90

Ø 5 mm

33 cm

Knotenschnürer / Knotenschieber Knot tightener / knot pusher

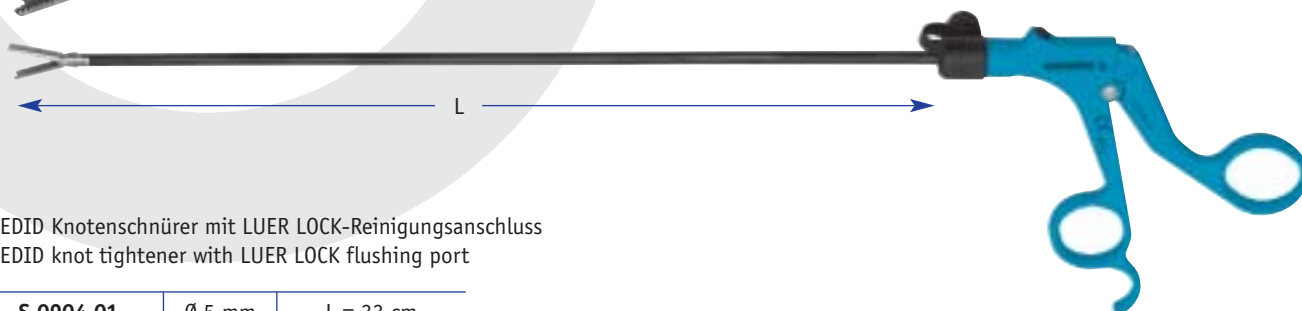

SHEDID Knotenschnürer mit LUER LOCK-Reinigungsanschluss
SHEDID knot tightener with LUER LOCK flushing port

S.0904.01	Ø 5 mm	L = 33 cm
------------------	--------	-----------



Knotenschieber mit Längsschlitz, Nutzlänge 33 cm
Knot pusher with slit, working length 33 cm

S.0901.02	Ø 5 mm	L = 33 cm
------------------	--------	-----------



Knotenschieber mit Oese, offen
Knot pusher with eye, open

S.0901.04	Ø 4 mm	L = 33 cm
------------------	--------	-----------



Knotenschieber mit Oese, geschlossen
Knot pusher with eye, closed

S.0901.06	Ø 3 mm	L = 30 cm
S.0901.08	Ø 5 mm	L = 30 cm



Knotenschieber mit Oese, offen
Knot pusher with eye, open

S.0901.10	Ø 3 mm	L = 30 cm
S.0901.12	Ø 5 mm	L = 30 cm



Endo-Retraktoren Ø 5 mm und 10 mm, Länge 33 cm, zerlegbar Endo retractors Ø 5 mm and 10 mm, length 33 cm, detachable



Instrument in zusammengebautem Zustand
Assembled instrument



Instrument in zerlegtem Zustand
Disassembled instrument



KOCHER-LANGENBECK Endo-Haken zur Retraktion/Dissektion, Nutzlänge 33 cm
KOCHER-LANGENBECK endo hook for retraction/dissection, working length 33 cm

Haken komplett Hook complete	Einsatz allein Insert only	Durchmesser Diameter	Maullänge Jaw length
T.5600.49	T.5600.39	Ø 5,0 mm	30 mm
T.5600.50	T.5600.40	Ø 5,0 mm	40 mm
T.5600.51	T.5600.41	Ø 5,0 mm	50 mm
T.5600.52	T.5600.42	Ø 10,0 mm	30 mm
T.5600.53	T.5600.43	Ø 10,0 mm	40 mm
T.5600.54	T.5600.44	Ø 10,0 mm	50 mm



CUSHING Endo-Retraktor, Nutzlänge 33 cm
CUSHING endo retractor, working length 33 cm angleable

Retraktor komplett Retractor complete	Einsatz allein Insert only	Durchmesser Diameter	Maullänge Jaw length
T.5601.52	T.5601.42	Ø 10,0 mm	30 mm
T.5601.53	T.5601.43	Ø 10,0 mm	40 mm
T.5601.54	T.5601.44	Ø 10,0 mm	50 mm



Endo-Retraktoren Ø 5 mm und 10 mm, Länge 33 cm, zerlegbar
Endo retractors Ø 5 mm and 10 mm, length 33 cm, detachable



Endo-Retraktor, fächerförmig, Nutzlänge 33 cm, (nicht abwinkelbar)
 Endo retractor, fan-shaped, working length 33 cm (not angleable)

Retraktor komplett Retractor complete	Einsatz allein Insert only	Durchmesser Diameter	Maullänge Jaw length
T.5644.49	T.5644.39	Ø 5,0 mm	50 mm
T.5644.50	T.5644.40	Ø 5,0 mm	60 mm
T.5644.51	T.5644.41	Ø 10,0 mm	50 mm
T.5644.52	T.5644.42	Ø 10,0 mm	60 mm



CUSHING Endo-Retraktor, Nutzlänge 33 cm abwinkelbar
 CUSHING endo retractor, working length 33 cm angleable

Retraktor komplett Retractor complete	Einsatz allein Insert only	Durchmesser Diameter	Maullänge Jaw length
T.5643.52	T.5643.42	Ø 10,0 mm	35 mm



Endo-Exzentrischer Retraktor, Nutzlänge 33 cm
 Endo eccentric retractor, working length 33 cm

Retraktor komplett Retractor complete	Einsatz allein Insert only	Durchmesser Diameter	Maullänge Jaw length
T.5642.52	T.5642.42	Ø 10,0 mm	60 mm

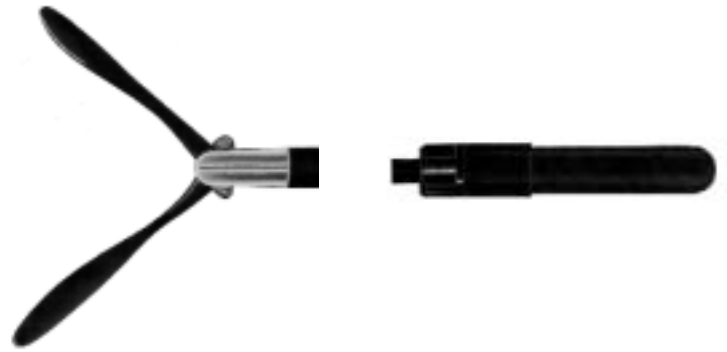

Handgriff
 Handle

T.5600.60	Ø 5,0 mm
T.5600.61	Ø 10,0 mm



Außenrohr
 Outer tube

T.5600.65	Ø 5,0 mm
T.5600.66	Ø 10,0 mm



Abwinkelbarer Endo-Retraktor, Ø 10 mm, zerlegbar, Nutzlänge 33 cm Angleable endo retractor, Ø 10 mm, detachable, working length 33 cm



Abwinkelbarer Endo-Retraktor, zerlegbar, mit 5 Spreizfingern
Angleable endo retractor, detachable, with 5 blades



T.5647.10

Ø 10 mm

**Optimale Reinigung und Sterilisation, da komplett zerlegbar
complete detachable, therefore optimal cleaning and sterilisation**

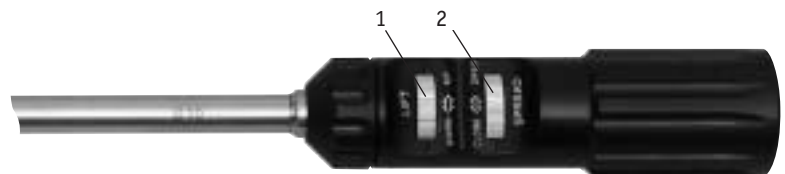
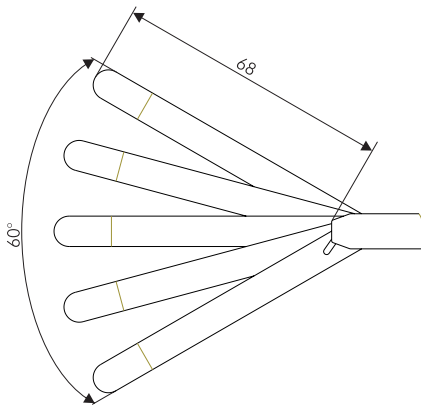

Das Arbeitsteil ist stufenlos bis zu 80° abwinkelbar.
Zum Abwinkeln, Stellrad (1) "Lift" drehen.
Zum Spreizen des Fächers, Rotationsrad (2) "Spread" drehen.

The jaw is stepless angleable up to 80°.
To angle the jaw parts, turn adjust wheel (1) "Lift".
To open the blades, turn rotating wheel (2) "Spread".

Endo-Retraktoren, Ø 5 mm und 10 mm, mit Reinigungsanschluss
Endo retractors Ø 5 mm and 10 mm, with flushing port



Endo - Retraktor mit 3 Spreizfingern und Reinigungsanschluss, starr
 Endo - retractor with 3 blades and flushing port, rigid

T.5645.05	Ø 5 mm	L = 34 cm
------------------	--------	-----------

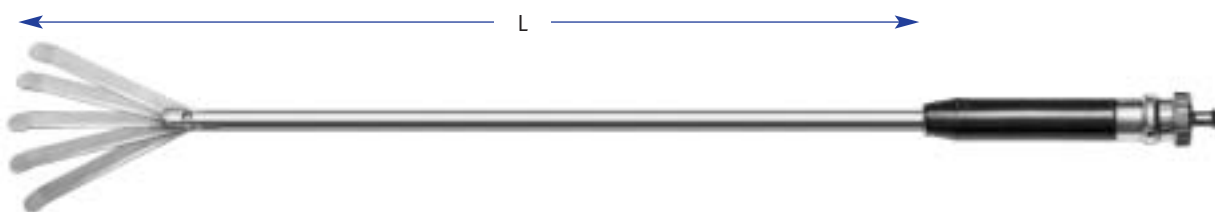

Endo-Retraktor, mit 5 Spreizfingern und Reinigungsanschluss, starr
 Endo retractor, with 5 blades and flushing port, rigid

T.5645.10	Ø 10 mm	L = 38 cm
------------------	---------	-----------



Endo-Retraktor, mit 3 Spreizfingern, abwinkelbar und Reinigungsanschluss
 Endo retractor, with 3 blades and flushing port, angleable

T.5646.05	Ø 5 mm	L = 34 cm
------------------	--------	-----------

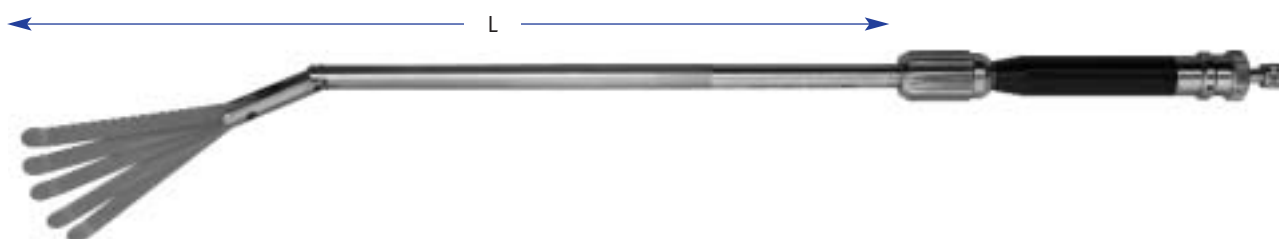





Endo-Retraktor, mit 5 Spreizfingern, abwinkelbar und Reinigungsanschluss
 Endo retractor, with 5 blades and flushing port, angleable

T.5646.10	Ø 10 mm	l = 38 cm
------------------	---------	-----------

Handgriffe für Saug-/Spülsystem Handles for suction/irrigation system

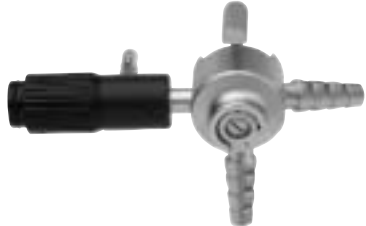

Adaptierbar mit monopolaren HF-Elektroden (T.0130.XX) Seite 77
Adaptable with monopolar HF-electrodes (T.0130.XX) Page 77

<p>T.0130.00</p>	<p>Pistolengriff mit Zweiwege-Ventil für auswechselbare HF-Elektroden mit Saug-/Spülkanal, Drehadapter mit seitlichem HF-Anschluß und 2 Universal-Schlauchanschlüssen</p> <p>Pistol handle with two-way valve, for exchangeable HF-electrodes with suction/irrigation channel, rotating adaptor with lateral HF-Connector and 2 universal tube connectors</p>	
<p>T.0130.01</p>	<p>Ventilhandgriff mit Doppeltrompetenventil, abnehmbarer Griffplatte für auswechselbare HF-Elektroden mit Saug-/Spülkanal, Drehadapter und seitlichem HF-Anschluß, Schlaucholive, sowie 1 Ventilanschluß LUER LOCK weiblich</p> <p>Handle with two trumpet valves, detachable handle plate for exchangeable HF-electrodes with suction/irrigation channel, rotating adaptor and lateral HF-connector, universal hose connector and 1 female LUER LOCK valve connector</p>	
<p>T.0130.02</p>	<p>Griff mit Trompetenventil für auswechselbare HF-Elektroden mit Saug-/Spülkanal, seitlichem HF-Anschluß und Schlauchanschluß</p> <p>Handle with trumpet valve, for exchangeable HF-electrodes with suction/irrigation channel, lateral HF-connector and tube connector</p>	
<p>T.0130.03</p>	<p>Griff mit Zweiwege-Schiebeventil für auswechselbare HF-Elektroden mit Saug-/Spülkanal, seitlichem HF-Anschluß und 2 Schlauchanschlüssen</p> <p>Handle with two-way sliding valve, for exchangeable HF-electrodes with suction/irrigation channel, lateral HF-connector and 2 tube connectors</p>	
<p>T.0130.05</p>	<p>Griff mit 2 Trompetenventilen für auswechselbare HF-Elektroden mit Saug-/Spülkanal, seitlichem HF-Anschluß, 2 LUER LOCK-Ventilanschlüssen und 1 Schlauchanschluß</p> <p>Handle with 2 trumpet valves for exchangeable HF-electrodes, with suction/irrigation channel, lateral HF-connector, 2 female LUER LOCK connectors and 1 tube connector</p>	

Adaptierbare monopolare HF-Elektroden mit Saug-/Spülkanal Adaptable monopolar HF-electrodes with suction/irrigation channel

Alle nachfolgenden HF-Elektroden mit Saug-/Spülkanal lassen sich an die Handgriffe der Serie **T.0130.XX** (Seite 76) adaptieren. Der Anschluß ist durch einen LUER LOCK-Anschluß, der außen zusätzlich durch ein O-Ring-System abgedichtet ist, zweifach abgesichert.

All following HF-electrodes with suction/irrigation channel can be used with all handles of series **T.0130.XX** (page 76)
The connection is very safe, using a LUER LOCK connector which is additionally tightened by an O-ring system.



T.0130.10	34 cm	Ø 5 mm	J-Haken-Elektrode J-Hook electrode	
T.0130.11	34 cm	Ø 5 mm	S-Haken-Elektrode S-Hook electrode	
T.0130.12	34 cm	Ø 5 mm	L-Haken-Elektrode L-Hook electrode	
T.0130.13	34 cm	Ø 5 mm	Spatel-Elektrode Spatula electrode	
T.0130.14	34 cm	Ø 5 mm	Kugel-Elektrode Ball electrode	
T.0130.16	34 cm	Ø 5 mm	Messer-Elektrode Blade electrode	
T.0130.15	34 cm	Ø 5 mm	45° Nadel-Elektrode 45° Needle electrode	
T.0130.17	34 cm	Ø 5 mm	Nadel-Elektrode Needle electrode	
T.0130.18	34 cm	Ø 5 mm	Konus-Elektrode Cone electrode	
T.0130.19	34 cm	Ø 5 mm	Saug-/Spülrohr Suction and irrigation tube	

Wir empfehlen max. 5 Anwendungen
We recommend max. 5 applications

Monopolare Laparoskopieelektroden mit Keramikisolation, Ø 5 mm, 36 cm lang Monopolar laparoscopy electrodes with ceramic tip insulation, Ø 5 mm, length 36 cm

Merkmale



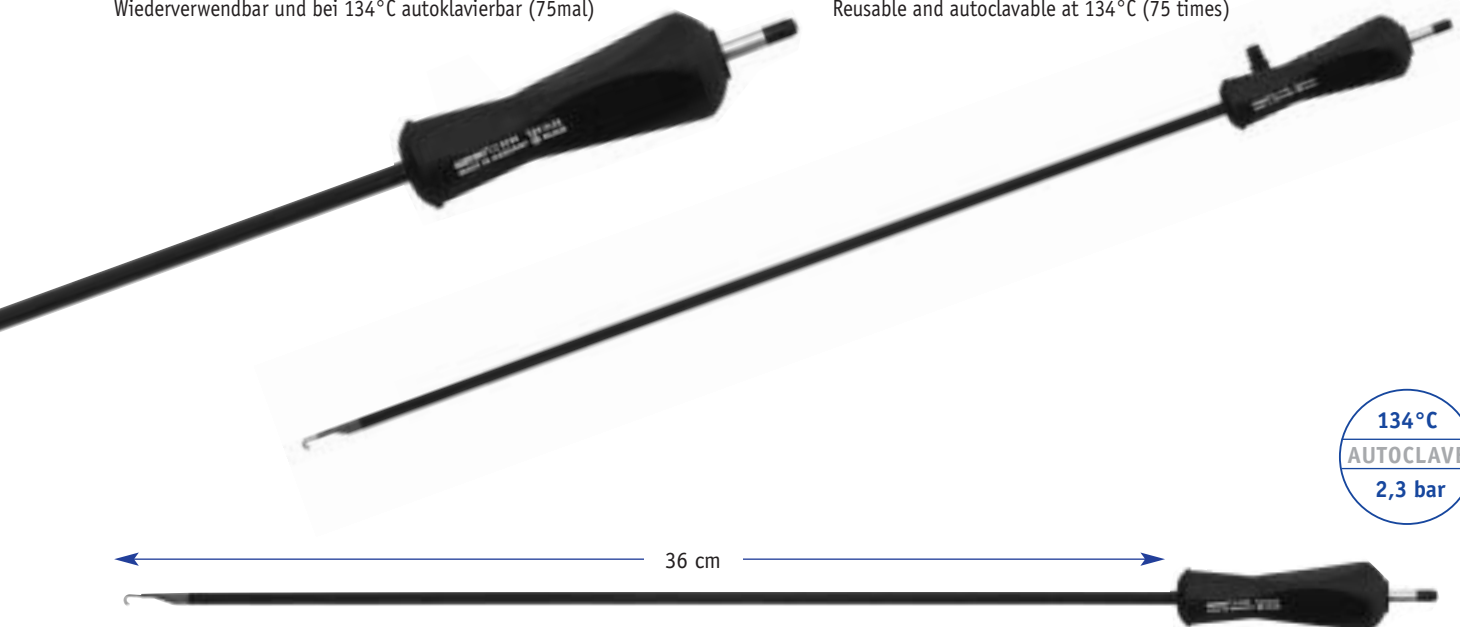

- Wahlweise mit oder ohne Saugrohr
- Arbeitslänge 36 cm
- Ergonomisches Design
- Modularer Aufbau
- Einsatz von High-Tech Kunststoffen
- Hochtemperaturfeste Spitzenisolierung aus Keramik
- Schaftisolation aus massivem PEEK
- Mit Universalschlauchanschluß für Silikonschläuche mit I-Ø 5/6 und 7 mm
- Wiederverwendbar und bei 134°C autoklavierbar (75mal)

Features

- Available with or without suction tube
- Working length 36 cm
- Ergonomic design
- Modular construction
- Use of high-tech plastics
- High temperature tip insulation made of ceramics
- Insulation of shaft by massive PEEK
- With universal tube connector for silicone tube with inner Ø of 5/6 and 7 mm
- Reusable and autoclavable at 134°C (75 times)



ohne Saugrohr
without suction tube

T.0210.06	L-Haken-Elektrode L-Hook electrode		1/1
T.0210.07	J-Haken-Elektrode J-Hook electrode		1/1
T.0210.08	Spatel-Elektrode Spatula electrode		1/1
T.0210.10	Kugel-Elektrode Ball electrode		1/1

Monopolare Laparoskopielektroden mit Keramikisolation, Ø 5 mm, 36 cm lang Monopolar laparoscopy electrodes with ceramic tip insulation, Ø 5 mm, length 36 cm

Merkmale





- Wahlweise mit oder ohne Saugrohr
- Arbeitslänge 36 cm
- Ergonomisches Design
- Modularer Aufbau
- Einsatz von High-Tech Kunststoffen
- Hochtemperaturfeste Spitzenisolation aus Keramik
- Schaftisolation aus massivem PEEK
- Mit Universalschlauchanschluß für Silikonschläuche mit I-Ø 5/6 und 7 mm
- Wiederverwendbar und bei 134°C autoklavierbar (75mal)

Features

- Available with or without suction tube
- Working length 36 cm
- Ergonomic design
- Modular construction
- Use of high-tech plastics
- High temperature tip insulation made of ceramics
- Insulation of shaft by massive PEEK
- With universal tube connector for silicone tube with inner Ø of 5/6 and 7 mm
- Reusable and autoclavable at 134°C (75 times)



mit Saugrohr
with suction tube

T.0210.05	L-Haken-Elektrode L-Hook electrode		1/1
T.0210.04	J-Haken-Elektrode J-Hook electrode		1/1
T.0210.01	Spatel-Elektrode Spatula electrode		1/1
T.0210.03	Kugel-Elektrode Ball electrode		1/1

Monopolare Lap-Elektroden Ø 5 mm, mit auswechselbaren Spitzen Monopolar lap electrodes Ø 5 mm, with exchangeable tips

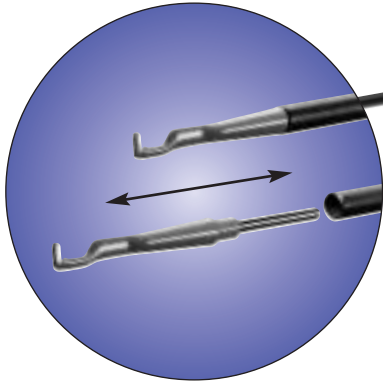

134°C
AUTOCLAVE
2,3 bar

Einfacher Elektrodenwechsel

Durch Drehen des Griffständels löst sich die Elektrodenspitze und kann einfach aus dem Schaft entnommen werden. Dadurch ist ein schneller, problemloser und kostengünstiger Austausch der Einzelteile möglich.







Easy exchange of electrodes

By turning the serrated wheel on the handle, the electrode tip is released and can be easily removed from the shaft. Therefore a quick, troublefree and cost effective exchange of the parts is enabled.



T.0118.00	32 cm	Ø 5 mm	Griff komplett
T.0118.45	45 cm	Ø 5 mm	Handle complete
T.0118.22	32 cm	Ø 5 mm	Isolierter Außenschaft allein
T.0118.24	45 cm	Ø 5 mm	Insulated outer shaft only







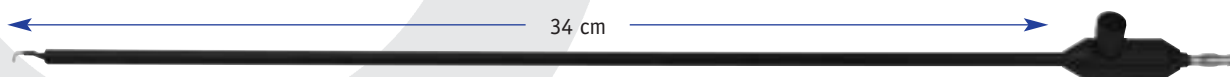

Auswechselbare monopolare Lap-Elektroden-Spitzen – wiederverwendbar Exchangeable monopolar lap electrodes tips – reusable

T.0118.01	J-Haken-Elektrode J-hook electrode	
T.0118.02	L-Haken-Elektrode L-hook electrode	
T.0118.03	Spatel-Elektrode Spatula electrode	
T.0118.04	Nadel-Elektrode Needle electrode	
T.0118.05	Kugel-Elektrode Ball electrode	
T.0118.06	Messer-Elektrode Blade electrode	
T.0118.20	Dichtringe für Elektroden Sealing O-rings for electrodes	

Monopolare Elektroden Ø 5 mm, Arbeitslängen 34 cm und 44 cm Monopolar electrodes Ø 5 mm, working lengths 34 cm and 44 cm



HF-Elektrode, monopolar, mit HF-Anschluss und seitlicher Spül-/Absaugmöglichkeit
HF electrodes, monopolar, with HF-connector and lateral suction/flush-port





T.0131.10	34 cm	Ø 5 mm	J-Haken-Elektrode J-Hook electrode	
T.0131.40	44 cm			
T.0131.11	34 cm	Ø 5 mm	S-Haken-Elektrode S-Hook electrode	
T.0131.41	44 cm			
T.0131.12	34 cm	Ø 5 mm	L-Haken-Elektrode L-Hook electrode	
T.0131.42	44 cm			
T.0131.13	34 cm	Ø 5 mm	Spatel-Elektrode Spatula electrode	
T.0131.43	44 cm			
T.0131.14	34 cm	Ø 5 mm	Kugel-Elektrode Ball electrode	
T.0131.44	44 cm			
T.0131.15	34 cm	Ø 5 mm	Messer-Elektrode Blade electrode	
T.0131.45	44 cm			
T.0131.16	34 cm	Ø 5 mm	45° Nadel-Elektrode 45° Needle electrode	
T.0131.46	44 cm			
T.0131.17	34 cm	Ø 5 mm	Nadel-Elektrode Needle electrode	
T.0131.47	44 cm			
T.0131.18	34 cm	Ø 5 mm	Konus-Elektrode Cone electrode	
T.0131.48	44 cm			

Wir empfehlen max. 5 Anwendungen.
We recommend max. 5 applications.

Koagulations-Saugkanülen/Elektroden, monopolar, Ø 5 mm, Arbeitslänge 33 cm Coagulation suction tubes/electrodes, monopolar, Ø 5 mm, working length 33 cm



Koagulationssaugrohre mit Trompetenventil
Coagulation tubes with trumpet valve

T.0021.05	33 cm	Ø 5 mm	Spatel-Elektrode Spatula electrode	
T.0022.05	33 cm	Ø 5 mm	J-Haken-Elektrode J-Hook electrode	
T.0023.05	33 cm	Ø 5 mm	L-Haken-Elektrode L-Hook electrode	
T.0024.05	33cm	Ø 5 mm	Kugel-Elektrode Ball electrode	
T.0020.05	33 cm	Ø 5 mm	Nadel-Elektrode Needle electrode	

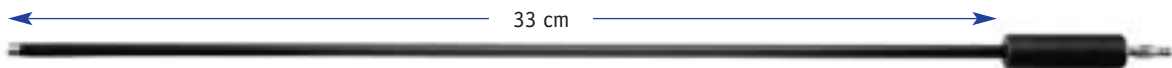

Elektroden, monopolar, massive Ausführung
Electrodes, monopolar, solid model





T.0025.05	33 cm	Ø 5 mm	Spatel-Elektrode Spatula electrode	
T.0026.05	33 cm	Ø 5 mm	J-Haken-Elektrode J-Hook electrode	
T.0027.05	33 cm	Ø 5 mm	L-Haken-Elektrode L-Hook electrode	
T.0028.05	33cm	Ø 5 mm	Kugel-Elektrode Ball electrode	
T.0028.06	33 cm	Ø 5 mm	Nadel-Elektrode Needle electrode	
T.0025.99	Komfort-Handgriff für Elektroden T.0025.05-T.0028.06 Comfort handle for electrodes T.0025.05-T.0028.06			

Koagulations-Saugkanülen/Elektroden, monopolar, Ø 5 mm, Arbeitslänge 33 cm Coagulation suction tubes/electrodes, monopolar, Ø 5 mm, working length 33 cm





Koagulationssaugrohr mit Trompetenventil, austauschbar
Coagulation tubes with trumpet valve, interchangeable



Komplett mit T.0120.05 Complete with T.0120.05	Aufsatz allein Tip only	Arbeitslänge Working length	Durchmesser Diameter		
T.0121.05	T.0125.05	33 cm	Ø 5 mm	Spatel-Elektrode Spatula electrode	
T.0122.05	T.0126.05	33 cm	Ø 5 mm	J-Haken-Elektrode J-Hook electrode	
T.0123.05	T.0127.05	33 cm	Ø 5 mm	L-Haken-Elektrode L-Hook electrode	
T.0124.05	T.0128.05	33 cm	Ø 5 mm	Kugel-Elektrode Ball electrode	
T.0121.06	T.0125.06	33 cm	Ø 5 mm	Nadel-Elektrode Needle electrode	



T.0120.05	Griff mit Trompetenventil Handle with trumpet valve	
T.0120.07	Griff mit 2 Trompetenventilen Handle with 2 trumpet valves	



Griff mit Schiebventil
Handle with sliding valve

T.0032.20

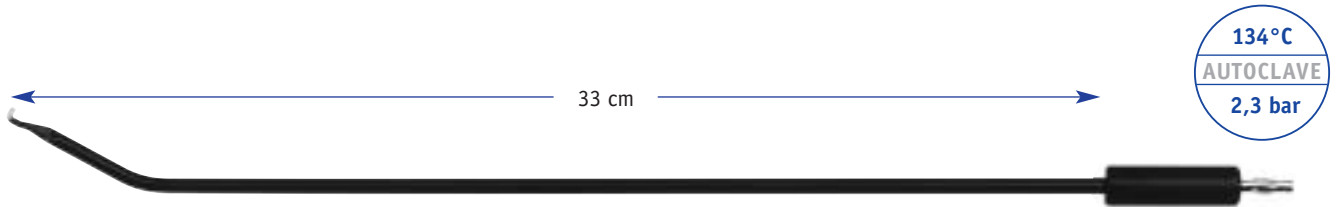
Koagulations-Saugkanülen / Elektroden, monopolar, Ø 5 mm, Arbeitslänge 33 cm Coagulation suction tubes / electrodes, monopolar, Ø 5 mm, working length 33 cm



Elektroden, monopolar, massive Ausführung
Electrodes, monopolar, solid model

T.0026.01	33 cm	Ø 5 mm	Spatel-Elektrode Spatula electrode	
T.0026.02	33 cm	Ø 5 mm	L-Haken-Elektrode L-Hook electrode	

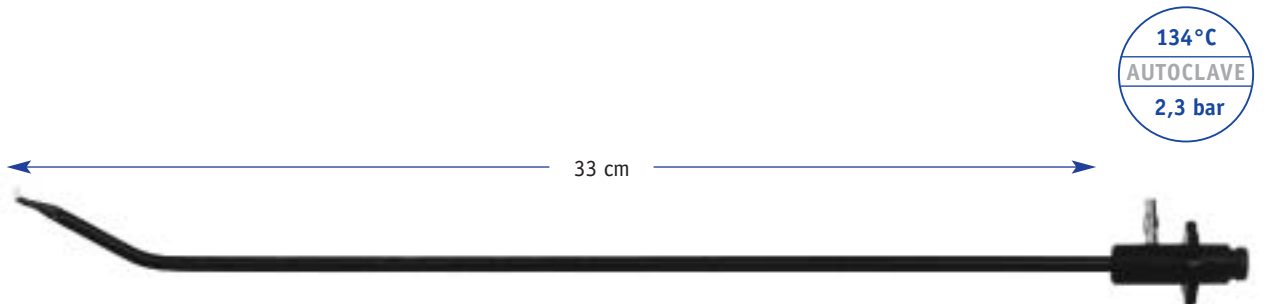

L-Haken-Elektrode, monopolar, auswechselbar
L-Hook electrode, monopolar, changeable

T.0026.04	33 cm	Ø 5 mm		
------------------	-------	--------	--	---



Saug-Spülrohr, auswechselbar
Suction-/ irrigation tube, exchangeable

T.0026.15				
------------------	--	--	--	--



Punktionsnadel-sauger, auswechselbar
Aspiration needle suction tube, exchangeable

T.0026.18				
------------------	--	--	--	--

T.0026.04 - T.0026.18 adaptierbar mit den Griffen auf Seite 83 (T.0120.05, T.0120.07 und T.0032.20)
T.0026.04 - T.0026.18 can be used with handles on page 83 (T.0120.05, T.0120.07 and T.0032.20)

Sicherheitskabel, monopolar, 3,5 mtr. lang
Safety cable, monopolar, length 3,5 mtr.



	Länge Length	Geräteseite Unit side		Instrumentenseite Instrument side
T.9539.06	3,5 mtr.	Erbe T-Serie GIMMI® Martin Berchtold	Ø 4,0 mm 	 Ø 4,0 mm
T.9539.05	3,5 mtr.	Erbe ACC/ICC Erbe VIO STORZ	Ø 5 mm 	 Ø 4,0 mm
T.9539.07	3,5 mtr.	Valleylab Conmed Bovie	Ø 8 mm 	 Ø 4,0 mm

einzigartige Sicherheitshülse - macht gewöhnliche 4 mm Stecker berührungssicher

unique safety sleeve - makes conventional 4 mm connectors touch-safe

fester Halt am Instrument durch vergoldete Lamellenkontakte
firm grip at the instrument due to gold-plated spring contacts

erfüllt die IEC Anforderungen
meets IEC requirements

hohe Lebensdauer
long-life

für alle gebräuchlichen Generatoren
for all common ESU's

Monopolare Anschlußkabel Monopolar connecting cables



	Länge Length	Geräteseite Unit side		Instrumentenseite Instrument side
T.9540.01	3 mtr.	Erbe T-Serie GIMMI® Martin Berchtold	Ø 4,0 mm	
T.9540.02	5 mtr.			
T.9543.01	3 mtr.	Erbe ACC/ICC Erbe VIO STORZ	Ø 5 mm	
T.9543.02	5 mtr.			
-	3 mtr.	GIMMI® Martin Berchtold		
T.9540.04	5 mtr.			
T.9539.03	3 mtr.	Valleylab Conmed Bovie	Ø 8 mm	
T.9539.08	5 mtr.			

	Länge Length	Geräteseite Unit side	Anschlußkabel, monopolar, für Laparoskopieelektroden Connection cable, monopolar, for laparoscopic electrodes	
T.9539.01	3 mtr.	GIMMI® Martin Berchtold Erbe T-Serie	Ø 4,0 mm	
T.9539.02	5 mtr.			

	Länge Length	Geräteseite Unit side		Instrumentenseite Instrument side
T.9539.04	3 mtr.		Ø 4,0 mm	 Ø 4,0 mm

ALPHAACTIVEGRIP

Bipolare Koagulationszangen/Scheren, Ø 5 mm, drehbar, zerlegbar, 34 cm und 45 cm Bipolar coagulation forceps/scissors, Ø 5 mm, rotatable, detachable, 34 cm and 45 cm

134°C
AUTOCLAVE
2,3 bar

Die GIMMI® *ALPHAACTIVEGRIP* Koagulationsinstrumente sind Instrumente zum Fassen, Schneiden und bipolaren Koagulieren in der Minimal Invasiven Chirurgie. Sie zeichnen sich durch einen neu entwickelten Mechanismus aus, der ein aktives, gut dosierbares Öffnen und Schließen der Maulteile und besonders hohen Druck beim Fassen und Schneiden bei gleichzeitiger präziser Koagulation des Gewebes ermöglicht. Dabei werden die Maulteile nicht, wie sonst üblich, durch Federwirkung, sondern über ein Doppelgelenk bewegt, welches über eine Schubstange sowohl elektrisch als auch mechanisch mit dem Handgriff verbunden ist.

In den besonders ergonomischen Handgriff aus hochwertigem PEEK-Kunststoff ist der Anschluss für standardisierte Bipolarkabel fest integriert. Dies erspart den Kauf teurer Spezialkabel und verhindert Verwechslungen.

Darüber hinaus bieten die GIMMI® *ALPHAACTIVEGRIP* weitere wichtige Vorteile:

- austauschbare Elektroden-Einsätze für verschiedene Einsatzbereiche
- einfachste Handhabung
- gute Reinigungsmöglichkeit und Reparaturfreundlichkeit

The GIMMI® *ALPHAACTIVEGRIP* coagulation instruments are used for grasping, cutting and bipolar coagulation in Minimally Invasive Surgery. They are characterized by a newly developed mechanism enabling highly adjustable opening and closing of the jaws with very high pressure, while grasping and cutting. This can be accompanied by precise coagulation of tissue. The jaws are not moved by spring power, but by a double hinge which is connected electrically and mechanically to the handle by a slide rod.

The connector for standard bipolar cables is integrated in the ergonomic handle, made of high quality PEEK polymer. This saves purchasing of expensive special cables and prevents them from being connected incorrectly. We supply standardized bipolar cables for connection to practically all common HF generators.

Beyond that, the GIMMI® *ALPHAACTIVEGRIP* offers the following important advantages:

- exchangeable electrode inserts for different applications
- easy handling
- excellent cleaning and easy repair



ALPHAACTIVEGRIP

Bipolare Koagulationszangen/Scheren, Ø 5 mm, drehbar, zerlegbar, 34 cm und 45 cm

Bipolar coagulation forceps/scissors, Ø 5 mm, rotatable, detachable, 34 cm and 45 cm



Die Instrumente sind in drei Einzelteile zerlegbar. Das ermöglicht zum einen eine gründliche, zuverlässige Reinigung und erleichtert zum anderen die Reparatur oder den Ersatz defekter Teile.

The instruments consist of three parts. This enables thorough and reliable cleaning and facilitates repair or the replacement of defective parts.

Griff
Handle

T.0050.10



Schaft
Shaft





T.0050.14

34 cm

T.0055.14

45 cm



Instrument komplett Complete instrument	Einsatz allein Insert only			
T.0050.00	T.0050.17	34 cm	Bipolare Fasszange Bipolar grasping forceps	
T.0055.00	T.0055.17	45 cm		
T.0050.04	T.0050.20	34 cm	MARYLAND Dissektor, gebogen MARYLAND dissector, curved	
T.0055.04	T.0055.20	45 cm		
T.0050.07	T.0050.23	34 cm	METZENBAUM Hartmetallschere, gebogen METZENBAUM tungsten carbide scissors, curved	
T.0055.07	T.0055.23	45 cm		
T.0050.03	T.0050.18	34 cm	Bipolare Fasszange, fein, Spitzen gezahnt Bipolar grasping forceps delicate, serrated tips	
T.0055.03	T.0055.18	45 cm		
T.0050.05	T.0050.19	34 cm	Bipolare Fasszange, gefenestert, gebogen Bipolar grasping forceps, fenestrated, curved	
T.0055.05	T.0055.19	45 cm		

new

new

Bipolare Koagulationszangen/Scheren, Ø 5 mm, drehbar, zerlegbar
Bipolar coagulation forceps/scissors, Ø 5 mm, rotatable, detachable



Ø 3 mm auf Anfrage
Ø 3 mm on request

Die wichtigsten Vorteile der neuen bipolaren Koagulationszange:

- zerlegbar, dadurch leichtes Reinigen
- 360° drehbar, bequeme Handhabung
- Arbeitsende **weicht beim Schließen nicht zurück**
- ergonomisches Design
- modularer Aufbau
- autoklavierbar 134°C

Important advantages of the new bipolar coagulation forceps:

- detachable, therefore easy to clean
- 360° rotatable, comfortable handling
- **no receding** of the working tip during closing
- ergonomic design
- modular construction
- autoclavable 134°C

Bipolare Koagulationszangen/Scheren, Ø 5 mm, drehbar, zerlegbar
Bipolar coagulation forceps/scissors, Ø 5 mm, rotatable, detachable

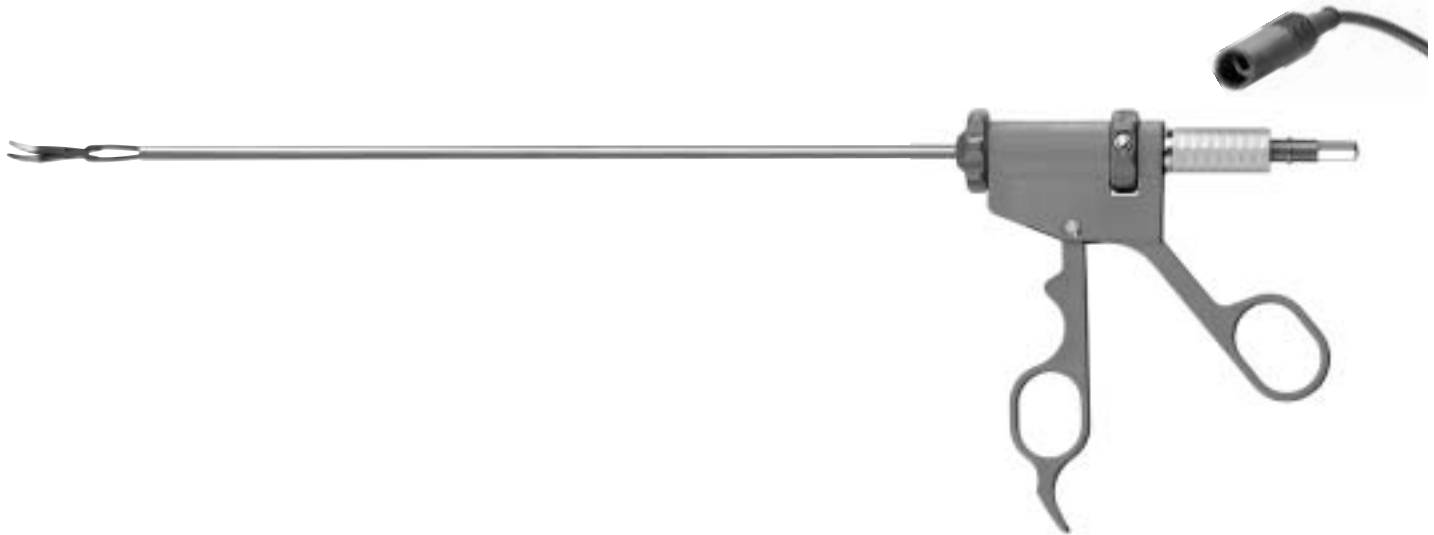

Die neue, wiederverwendbare bipolare Scherenelektrode für die Laparoskopie ermöglicht Dissektion und Schneiden bei gleichzeitiger Koagulation.

Ein Instrumentenwechsel ist nicht mehr erforderlich

The new, reusable bipolar scissor electrode for laparoscopy provides the ability to dissect, cut and coagulate at the same time.

Changing instruments is no longer necessary.

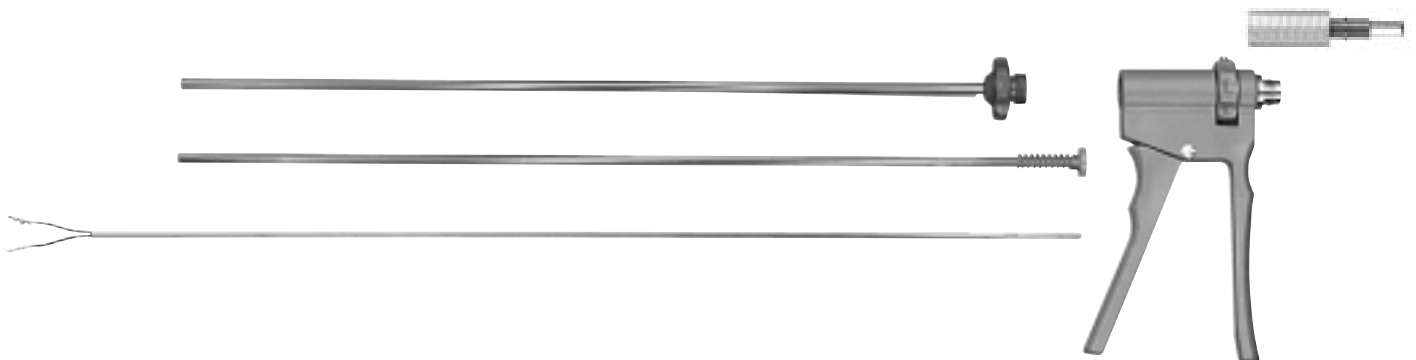

Die Zange ist in 5 Einzelteile zerlegbar: Griff - Innenrohr - Außenrohr - Zangeneinsatz/Elektrode - Adapter
 The forceps consist of 5 parts: handle - inside tube - outer tube - forceps insert/electrode - adaptor

Bipolare Koagulationszangen/Scheren, Ø 5 mm, drehbar, zerlegbar
Bipolar coagulation forceps/scissors, Ø 5 mm, rotatable, detachable



Griff
Handle

T.0013.20



Ring-Griff
Ring handle

T.0014.20



Flachstecker Adapter allein
Flat plug adaptor only

T.0013.25



2-Pin Adapter allein
2-Pin adaptor only









T.0013.28

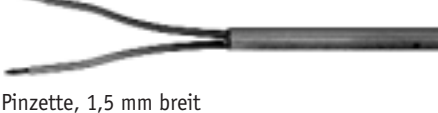

T.0013.26	20 cm	Außenrohr allein Outer tube only	
T.0013.21	34 cm		
T.0013.23	45 cm		
T.0013.27	20 cm	Innenrohr allein Inside tube only	
T.0013.22	34 cm		
T.0013.24	45 cm		

Bipolare Koagulationszangen/Scheren, Ø 5 mm, drehbar, zerlegbar Bipolar coagulation forceps/scissors, Ø 5 mm, rotatable, detachable

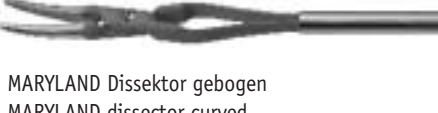

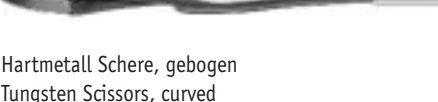
						Länge length	
Instrument komplett, inklusive Adapter mit Flachstecker Instrument complete, including adaptor with flat plug		Elektrode allein Electrode only					
T.0013.06	T.0014.76	T.0013.16				20 cm	Maulteil gefenestert Jaw fenestrated
T.0013.00	T.0014.70	T.0013.10				34 cm	
T.0013.01	T.0014.71	T.0013.11				45 cm	
T.0013.07	T.0014.77	T.0013.18				20 cm	 Maulteil 3 mm breit, glatt Jaw 3 mm wide, smooth
T.0013.02	T.0014.72	T.0013.12				34 cm	
T.0013.03	T.0014.73	T.0013.13				45 cm	
T.0013.08	T.0014.78	T.0013.17				20 cm	 Pinzette, 1,5 mm breit Forceps 1.5 mm wide
T.0013.04	T.0014.74	T.0013.14				34 cm	
T.0013.05	T.0014.75	T.0013.15				45 cm	
T.0013.40	T.0014.80	T.0013.30				20 cm	 KLEPPINGER gerieft KLEPPINGER serrated
T.0013.41	T.0014.81	T.0013.31				34 cm	
T.0013.42	T.0014.82	T.0013.32				45 cm	
T.0013.44	T.0014.22	T.0014.17				20 cm	 MARYLAND Dissektor gebogen MARYLAND dissector curved
T.0013.45	T.0014.23	T.0014.18				34 cm	
T.0013.46	T.0014.24	T.0014.19				45 cm	
T.0013.47	T.0014.02	T.0014.12				20 cm	 Schere, gebogen Scissors, curved
T.0013.48	T.0014.00	T.0014.10				34 cm	
T.0013.49	T.0014.01	T.0014.11				45 cm	
T.0013.50	T.0014.06	T.0014.15				20 cm	 Hartmetall Schere, gebogen Tungsten Scissors, curved
T.0013.51	T.0014.07	T.0014.13				34 cm	
T.0013.52	T.0014.08	T.0014.14				45 cm	

Bipolare Koagulationszange, Ø 5 mm, zerlegbar
Bipolar coagulation forceps, Ø 5 mm, detachable



Die Zange ist in 3 Einzelteile zerlegbar: Griff - Kunststoffrohr - Zangeneinsatz/Elektrode
 The forceps consist of 3 parts: handle - plastic tube - forceps insert/electrode



Griff
 Handle

T.0002.20



Kunststoffrohr
 Plastic tube

T.0001.33 33 cm

T.0001.45 45 cm



Bipolare Koagulationszange, zerlegbar, Ø 5 mm, mit Federgriff, **Flachstecker-Anschluß**
 Bipolar coagulation forceps, detachable, Ø 5 mm, with spring handle, **flat plug connector**

Zange komplett Forceps complete	Elektrode allein Electrode only	Länge Length		
T.0002.33	T.0002.30	33 cm	Maulteil gefenstert Jaw fenestrated	
T.0002.45	T.0002.40	45 cm		
T.0003.33	T.0003.30	33 cm	Maulteil 3 mm breit, glatt Jaw 3 mm wide	
T.0003.45	T.0003.40	45 cm		
T.0003.53	T.0003.50	33 cm	Maulteil 1,5 mm breit Jaw 1.5 mm wide	
T.0003.65	T.0003.60	45 cm		
T.0004.33	T.0004.30	33 cm	Pinzette 1,5 mm breit Jaw 1.5 mm wide	
T.0004.45	T.0004.40	45 cm		

Bipolare Koagulationszange, Ø 5 mm, zerlegbar Bipolar coagulation forceps, Ø 5 mm, detachable

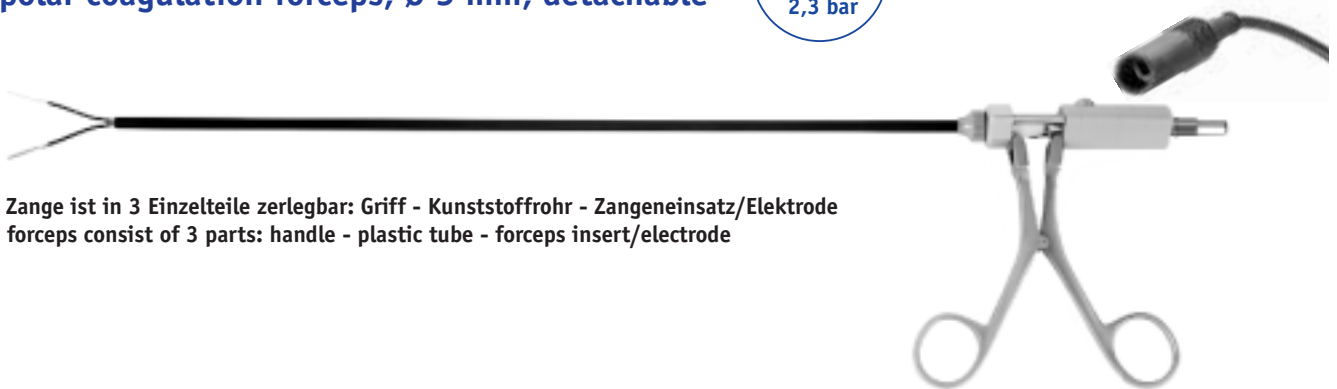

Die Zange ist in 3 Einzelteile zerlegbar: Griff - Kunststoffrohr - Zangeneinsatz/Elektrode
The forceps consist of 3 parts: handle - plastic tube - forceps insert/electrode

Griff
Handle

T.0011.20

Kunststoffrohr
Plastic tube

T.0001.33 33 cm

T.0001.45 45 cm



Bipolare Koagulationszange, **mit Ringgriff**, zerlegbar, Ø 5 mm, **Flachstecker-Anschluß**
Bipolar coagulation forceps, **with ring handle**, detachable, Ø 5 mm, **flat plug connector**

Zange komplett Forceps complete	Elektrode allein Electrode only	Länge Length		
T.0011.00	T.0002.30	33 cm	Maulteil gefenstert Jaw fenestrated	
T.0011.01	T.0002.40	45 cm		
T.0011.02	T.0003.30	33 cm	Maulteil 3 mm breit, glatt Jaw 3 mm wide	
T.0011.04	T.0003.40	45 cm		
T.0011.08	T.0003.50	33 cm	Maulteil 1,5 mm breit Jaw 1.5 mm wide	
T.0011.09	T.0003.60	45 cm		
T.0011.06	T.0004.30	33 cm	Pinzette 1,5 mm breit Jaw 1.5 mm wide	
T.0011.07	T.0004.40	45 cm		

Bipolare Koagulationszange, Ø 5 mm, zerlegbar
Bipolar coagulation forceps, Ø 5 mm, detachable



Die Zange ist in 3 Einzelteile zerlegbar: Griff - Kunststoffrohr - Zangeneinsatz/Elektrode
 The forceps consist of 3 parts: handle - plastic tube - forceps insert/electrode

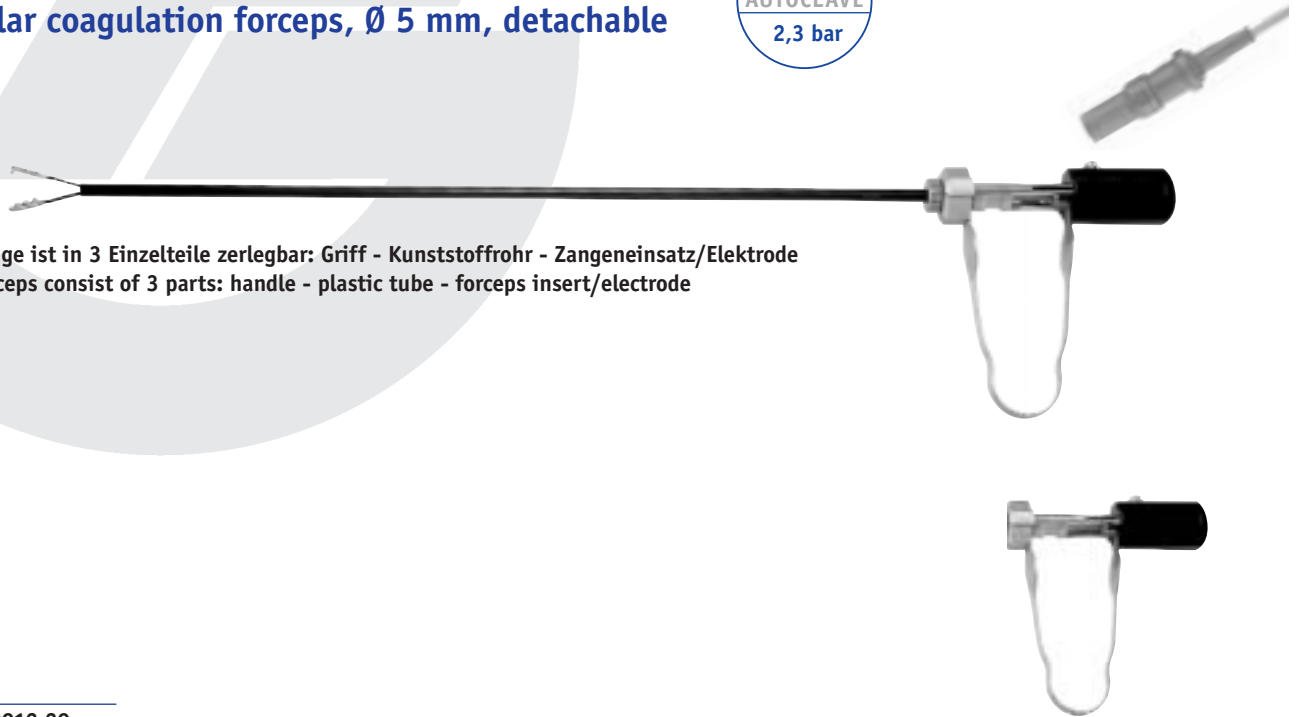

Griff
 Handle

T.0012.20

Kunststoffrohr
 Plastic tube

T.0012.33	33 cm
T.0012.45	45 cm







Bipolare Koagulationszange, zerlegbar, Ø 5 mm, mit Federgriff, **Rundstecker / Storz Anschluß**
 Bipolar Coagulation forceps, detachable, Ø 5 mm, with spring handle, **round plug / Storz connector**

Zange komplett Forceps complete	Elektrode allein Electrode only	Länge Length		
T.0012.02	T.0012.12	33 cm	Maulteil gefenstert Jaw fenestrated	
T.0012.03	T.0012.13	45 cm		
T.0012.04	T.0012.14	33 cm	Maulteil 3 mm breit, glatt Jaw 3 mm wide	
T.0012.05	T.0012.15	45 cm		
T.0012.06	T.0012.16	33 cm	Maulteil 1,5 mm breit Jaw 1.5 mm wide	
T.0012.07	T.0012.17	45 cm		
T.0012.00	T.0012.10	33 cm	Pinzette 1,5 mm breit Jaw 1.5 mm wide	
T.0012.01	T.0012.11	45 cm		

Bipolare Koagulationselektroden, Ø 5 mm, Nutzlänge 33 cm Bipolar coagulation electrodes, Ø 5mm, working length 33 cm







Bipolare Koagulationselektroden, Nutzlänge 33 cm
Bipolar coagulation electrodes, working length 33 cm

T.0015.05	Ø 5 mm	L-Haken-Elektrode L-Hook electrode	
T.0016.05	Ø 5 mm	J-Haken-Elektrode J-Hook electrode	
T.0017.05	Ø 5 mm	Kugel-Elektrode Ball electrode	
T.0017.06	Ø 5 mm	Bajonett-Nadel-Elektrode Bayonet needle electrode	

Bipolare Koagulationselektroden, Ø 5 mm, Nutzlänge 34 cm
Bipolar coagulation electrodes, Ø 5 mm, working length 34 cm



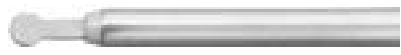

























Bipolare Koagulationselektroden, Nutzlänge 34 cm
 Bipolar coagulation electrodes, working length 34 cm

T.0018.01	Ø 5 mm	J-Haken-Elektrode J-Hook electrode	
T.0018.02	Ø 5 mm	L-Haken-Elektrode L-Hook electrode	
T.0018.03	Ø 5 mm	Spatel-Elektrode Spatula electrode	
T.0018.04	Ø 5 mm	Kuppel-Elektrode Ball electrode	
T.0018.05	Ø 5 mm	Teller-Elektrode Spoon electrode	

















Bipolare Anschlußkabel Bipolar connecting cables



	Länge Length	Geräte- Unit side		Instrumentenseite - Flachstecker Instrument side - flat plug
T.5768.05	3,0 mtr.	Erbe Wisap Storz		 
T.5768.08	5,0 mtr.			
T.5768.06	3,0 mtr.	GIMMI® Martin, Berchtold		 
T.5768.65	5,0 mtr.			
T.5768.07	3,0 mtr.	US-Units, 2 Banana plugs		 
T.5768.17	5,0 mtr.			
T.5768.67	3,0 mtr.	Valleylab Lamidey EMC	 28,58 mm	 
T.5768.68	5,0 mtr.			
T.5768.95	3,0 mtr.	Erbe Wisap Storz		 
T.5768.96	3,0 mtr.	GIMMI® Martin Berchtold		 
T.5768.97	3,0 mtr.	US-Units 2 Banana plugs		 
T.5767.04	3,0 mtr.	Valleylab Lamidey EMC	 28,58 mm	 
T.5767.06	5,0 mtr.			
T.5767.08	3,0 mtr.	EMC Dolley	 22 mm	 
T.5767.10	5,0 mtr.			

Bipolare Anschlußkabel Bipolar connecting cables

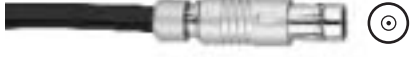

	Länge Length	Geräte- Unit side		Instrumentenseite - Rundstecker Instrument side - round plug
T.5768.03	3,0 mtr.	Erbe Wisap Storz		
T.5768.13	5,0 mtr.			
T.5768.04	3,0 mtr.	GIMMI® Martin Berchtold		
T.5768.64	5,0 mtr.			
T.5766.00	3,0 mtr.	US-Units 2 Banana plugs		
T.5766.06	5,0 mtr.			
T.5766.02	3,0 mtr.	Valleylab Lamidey EMC	 28,58 mm	
T.5766.04	5,0 mtr.			
T.5767.14	4,0 mtr.	Erbe Wisap Storz		
T.5767.12	4,5 mtr.	GIMMI® Martin Berchtold		
T.5767.18	4,5 mtr.	US-Units 2 Banana plugs		
T.5767.20	4,5 mtr.	Valleylab Lamidey EMC	 28,58 mm	
T.5767.00	3,0 mtr.	US-Units 2 Banana plugs		
T.5767.02	5,0 mtr.			

Simulations-Trainer Simulation Trainer

Die Kunst des endoskopischen Operierens ist nicht durch Assistenz erlernbar, wie z.B. bei der Laparatomie. Der Simulations-Trainer ermöglicht ein realistisches Training der Minimal Invasiven Chirurgie.

In contrast to laparatomic procedures, the art of performing endoscopic operations cannot be aquired by assistance in the operating theatre. The Simulation-Trainer is an optimum training device for learning the technique of Minimal Invasive Surgery.



Simulations-Trainer
Simulation trainer

T.1000.00

Ersatz-Membrane, 5 Stück
Spare membranes, 5 each

T.1000.01

Sterilisations-Zubehör für Endoskopie-Instrumente Sterilizing accessories for endoscopic instruments



Optik Behälter für zwei Ø 1-10 mm Optiken bis 45 cm Gesamtlänge
Scope tray for two Ø 1-10 mm scopes up to 45 cm length

T.1002.00	457 x 70 x 35 mm
------------------	------------------

Optik Behälter für zwei Optiken Ø 1-10 mm bis 39 cm Gesamtlänge
Scope tray for two scopes Ø 1-10 mm to 39 cm length

T.1002.02	394 x 70 x 35 mm
------------------	------------------

Optik Behälter für zwei Arthroskope / Sinuskope
Scope tray for two Arthroscopes / Sinusscopes

T.1002.04	275 x 76 x 32 mm
------------------	------------------



Universal Sterilisationsbehälter
für drei Optiken 5 mm oder 10 mm und Kaltlichtkabel

Universal sterilization tray
for three scopes 5 mm or 10 mm and fibre optic light cable

T.1002.06	465 x 212 x 51 mm
------------------	-------------------

Universal Sterilisationsbehälter mit zwei Silikonmatten
Universal sterilization tray with two silicone mats

T.1002.08	464 x 229 x 51 mm
------------------	-------------------



Mehr Container finden Sie in unserem Container Katalog Nr. 310
For more containers, see Container Catalogue No. 310

Sterilisations-Zubehör für Endoskopie-Instrumente Sterilizing accessories for endoscopic instruments



Universal Sterilisationsbehälter mit zwei Silikonmatten
Universal sterilization tray with two silicone mats

T.1002.10	502 x 239 x 102 mm
------------------	--------------------



Sterilisationsbehälter für Instrumente mit Ø 5 mm und Ø 10 mm
Sterilization tray for instruments with Ø 5 mm and Ø 10 mm

T.1001.00	464 x 190 x 70 mm
------------------	-------------------

Sterilisationsiebkorb für Optiken,
Sterilization wire basket for telescopes

T.1002.99	455 x 80 x 52 mm (1 Endoscope Ø 2 - 10 mm)
T.1002.96	455 x 80 x 52 mm (2 Endoscope Ø 2 - 10 mm)
T.1002.97	290 x 80 x 52 mm (1 Arthro / ENT Endoscope Ø 2 - 5 mm)
T.1002.98	670 x 80 x 52 mm (1 Endoscope Ø 2 - 10 mm)
T.1002.95	670 x 50 x 77 mm (1 Endoscope Ø 2 - 10 mm, cold light cable, small-parts box, etc.)

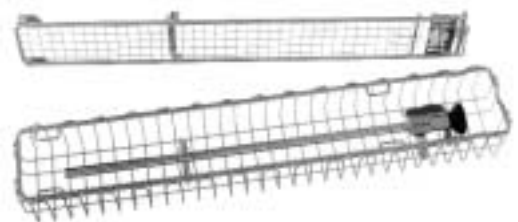

Mehr Container finden Sie in unserem Container Katalog Nr. 310
For more containers, see our Container Catalogue No. 310

Sterilisations-Zubehör für Endoskopie-Instrumente Sterilizing accessories for endoscopic instruments

Set bestehend aus:

- 1 R.0320.50 Container
- 2 R.0440.20 Silikon Matte
- 1 T.1002.93 Sterilisiergestell

Set consisting of:

- 1 R.0320.50 Container
- 2 R.0440.20 Silicone mat
- 1 T.1002.93 Storage and sterilization rack

R.0320.00

580 x 280 x 200 mm



Container
Container

R.0320.50

580 x 280 x 200 mm



Lagerungs- und Sterilisiergestell für 15 MIC Instrumente
Storage and sterilization rack for 15 MIC instruments

T.1002.93



Autoklavierbare Schutzhülsen für Endoskope bis Ø 4 mm,
(Box 10 Stück) durch Zusammenstecken von 2 Hülsen
erweiterbar für Urologie / Gynäkologie - Optiken

Autoclavable protection tubes for telescopes up to Ø 4mm,
(box 10 pcs.) assembling of two tubes will allow protection for
Urology / Gynaecology scopes

T.1002.90





134°C
AUTOCLAVE
2,3 bar

Mehr Container finden Sie in unserem Container Katalog Nr. 310
For more containers, see our Container Catalogue No. 310

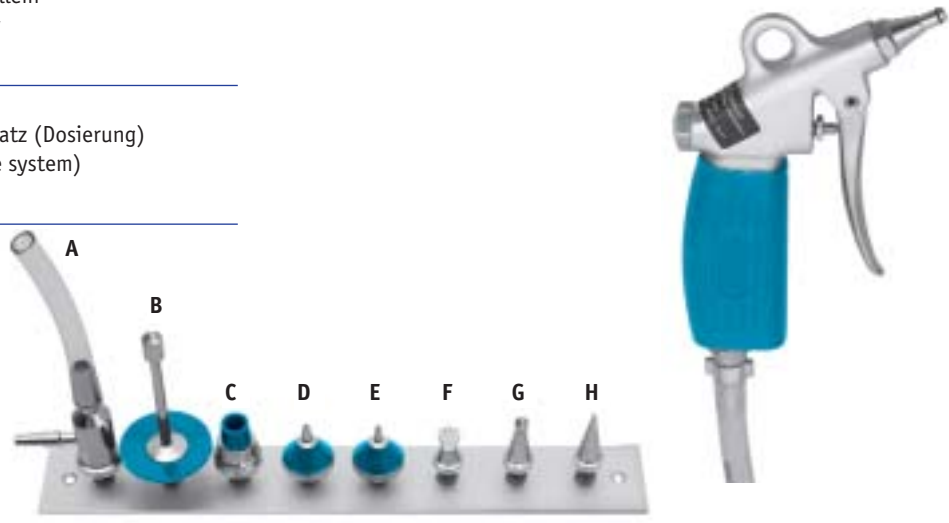
Zubehör für die Reinigung / Pflege Accessories for cleaning and care

T.1003.00	Reinigungspistole, komplett mit 8 Adaptern (an Wasserhahn oder zentrale Druckluftanlage anschließbar) Cleaning pistol, complete with 8 adaptors (attachable to standard water tap or compressed-air system)	
T.1003.04	Reinigungspistole allein Cleaning pistol only	
T.1003.05	Ersatzteil Nachrüstsatz (Dosierung) Spare parts (dosage system)	
T.1003.06	A	
T.1003.07	B	
T.1003.08	C	
T.1003.09	D	
T.1003.10	E	
T.1003.11	F	
T.1003.12	G	
T.1003.13	H	

Reinigungsbürste, Länge 49 cm (Packung à 10 Stück)
Cleaning brush, length 49 cm (10 pcs. p. box)

T.1003.50	für / for Ø 5 mm	
T.1003.51	für / for Ø 10 mm	

Spezialöl zur Instrumentenpflege
Special oil for instrument care

J.8860.06



Tips zur Instrumentenpflege

Ein sehr wichtiger Punkt ist die Pflege und Aufbereitung von Instrumenten.

Um die Funktionsfähigkeit und den Wert der Instrumente zu erhalten, ist es außerordentlich wichtig, folgende Regeln für die Instrumentenaufbereitung zu beachten:

1. Reinigung:

Die Instrumente müssen unmittelbar nach dem Gebrauch gereinigt werden. Zunächst sind die Operationsrückstände (Blut, Sekret, Gewebe etc.) abzuspielen. Zerlegbare Instrumente müssen zu diesem Zweck demontiert werden.

Für die **manuelle Reinigung** sollten hier weiche Reinigungstücher oder weiche Bürsten verwendet werden.

Bei der **maschinellen Reinigung** müssen die Instrumente in geeigneten Siebkörben nebeneinander gelagert werden.

Instrumente mit beweglichen Gelenken wie Klemmen, Scheren und Nadelhalter müssen mit geöffnetem Schluß gereinigt werden.

Bezüglich der verwendeten Reinigungs- und Desinfektionsmittel sind die Herstellerangaben genauestens zu beachten, ebenso die Bedienungsanleitungen für die zur Anwendung kommenden Maschinen bzw. Geräte.

Wichtig: Verwenden Sie täglich frisches Lösungsmittel

Achtung: fabrikneue Instrumente müssen vor der ersten Sterilisation gründlich gereinigt werden.

2. Spülung:

Nach der Reinigung / Desinfektion müssen die Instrumente mit klarem Wasser nachgespült werden. Es empfiehlt sich hier die Verwendung von vollentsalztem Wasser.

3. Trocknung:

Im Anschluß an die Spülung müssen die Instrumente sofort getrocknet werden. Wasserrückstände können zu Korrosion führen.

4. Prüfung:

Beschädigte oder fleckige Instrumente müssen aussortiert und zur Reparatur gegeben oder einer Sonderbehandlung unterzogen werden.

5. Pflege:

Instrumente mit Gelenken (Klemmen, Scheren etc.) müssen mit silikonfreiem Öl auf Paraffinbasis behandelt werden. (GIMMI-Nr. J.8860.06)

6. Sterilisation:

Dampfsterilisation: 134°C / 2 bar

bitte nur für Sterilisierzwecke geeigneten Dampf verwenden (DIN 58946, Teil 7 und Empfehlung der Norm pr EN 285 beachten).

Heißluftsterilisation: 180°C - 200°C

hierbei ist auf die allgemeine Anwendung von Pflegemitteln zu verzichten. Nur die Gelenke sind gezielt zu ölen.

Zur Vermeidung von Schäden an den Instrumenten durch das Erhitzen und Abkühlen während der Sterilisation, dürfen Instrumente mit Rastensperren nur geöffnet oder in der ersten Raste geschlossen sterilisiert werden.

Hints for instrument care

Care preparation and maintenance of instruments is a very important issue.

To secure the functional capability and value of instruments, it is very important to pay attention to the following rules:

1. Cleaning:

The instruments have to be cleaned **immediately** after use.

First you have to rinse them to remove any human tissue/residue (blood, secretions, tissue). Detachable instruments must be disassembled.

In case of **manual cleaning**, please clean with soft textile cloths or soft brushes.

In case of **mechanical cleaning** the instruments must be stored on instrument carriers suitable for cleaning.

Moving instruments like forceps, scissors and needle holders must be opened before cleaning.

In regard to cleaning and disinfection agents, please consider concentration, temperature and effecting times given by the manufacturer. Follow the operating instructions of the used machines.

Important: Use fresh solutions every day.

Attention: Brand new instruments must be cleaned, as explained above, before the first sterilization.

2. Rinsing:

After cleaning / disinfection the instruments must be rinsed, preferably with demineralized water.

3. Drying:

After rinsing the instruments must be dried **immediately**.

Remaining water may cause corrosion.

4. Inspection:

Damaged, spotted or stained instruments must be sorted out and treated in a special way or be repaired.

5. Care:

Moving instruments (forceps, scissors needle holders) must be treated with a silicone free oil on paraffin base.

(GIMMI-No. J.8860.06)

6. Sterilization:

Steam sterilization: 134°C / 2 bar

please use specific steam for sterilization purposes (DIN 58946, Part 7 and recommendation of pr EN 285)

Hot air sterilization: 180°C - 200°C

please do not use agents for general surface protection, only joints and locks must be oiled.

To avoid damage on instruments with ratchets, as a result of heating and cooling during the sterilizing process, the instruments must be opened, or closed in the first ratchet position only.

So finden Sie uns:

- aus Stuttgart kommend: A 81 Abfahrt Tuningen, auf B 523 Richtung Tuttlingen
- aus Zürich kommend: A 81 Richtung Stuttgart, Abfahrt Geisingen auf B 311 Richtung Tuttlingen
- aus Freiburg kommend: auf B 31 Richtung Donaueschingen
- aus Ulm kommend: B 311 Richtung Donaueschingen

in Tuttlingen: Richtung Donautal, Industriegebiet Rudolf-Diesel-Straße, dann Querstrasse: Carl-Zeiss-Straße

How to find us:

- from Stuttgart: A 81 exit Tuningen, on B 523 direction Tuttlingen
- from Zürich: A 81 direction Stuttgart, exit Geisingen on B 311 direction Tuttlingen
- from Freiburg: on B 31 direction Donaueschingen
- from Ulm: B 311 direction Donaueschingen

in Tuttlingen: direction Donautal, Industriegebiet Rudolf-Diesel-Straße, than Carl-Zeiss-Straße

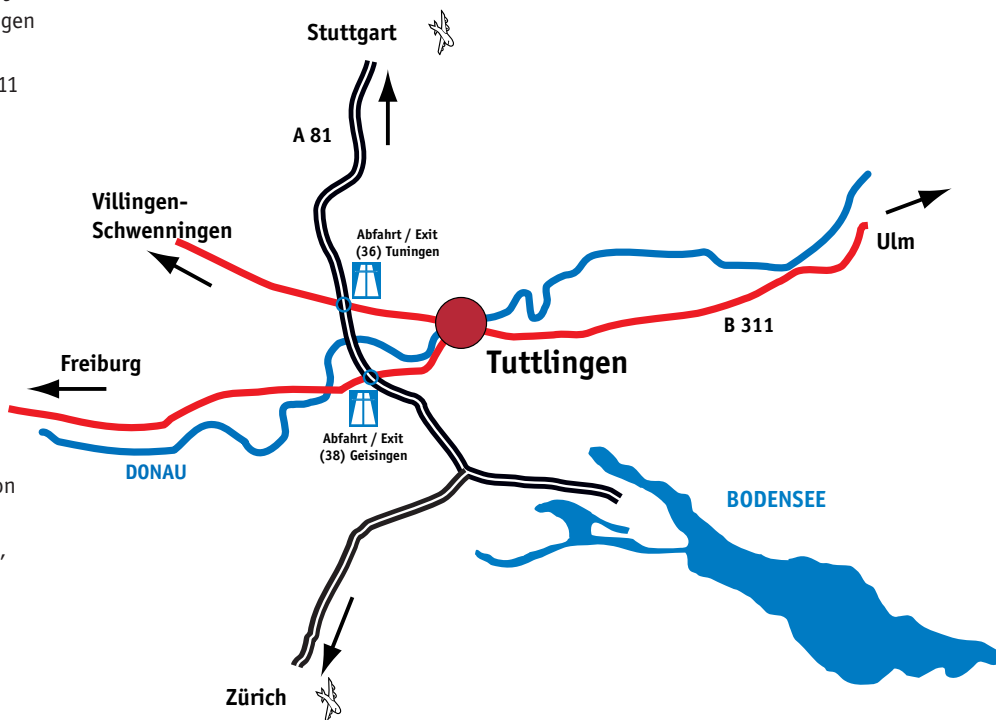

Dónde encontrarnos:

- desde Stuttgart: salida A 81 Tunigen, por la B 523 en dirección Tuttlingen
- desde Zurich: A 81 dirección Stuttgart, salida Geisingen por la B 311 dirección Tuttlingen
- desde Friburgo: por la B 31 en dirección Donaueschingen
- desde Ulm: B 311 en dirección Donaueschingen

en Tuttlingen; dirección Donautal Área industrial Rudolf-Diesel-Strasse, a continuación Carl-Zeiss-Strasse

Come raggiungerci:

- provenienti da Stoccarda: A 81, uscita Tuningen, imboccare la B 523 in direzione Tuttlingen
- provenienti da Zurigo: A 81, uscita Geisingen, imboccare la B 311 in direzione Tuttlingen
- provenienti da Friburgo: B 31 in direzione Donaueschingen
- provenendo da Ulm: B 311 in direzione Donaueschingen

a Tuttlingen: direzione Donautal, Industriegebiet Rudolf-Diesel-Straße, poi la traversa: Carl-Zeiss-Straße

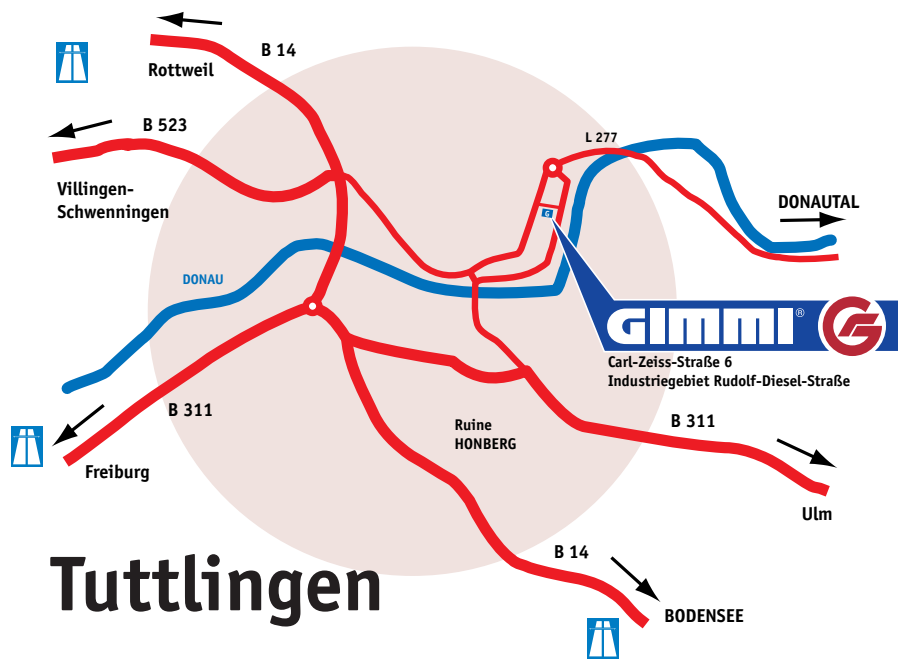



GIMMI® GmbH

Endoscopic Technology

Carl-Zeiss-Straße 6
D-78532 Tuttlingen

Telefon + 49 74 61 / 96 590-0
Telefax + 49 74 61 / 96 590-33

email info@gimmi.de

website www.gimmi.de

www.gimmi-germany.com